

IBEXA1
MID SIZE TRUCK - SHORT BED

Mid Height Configuration

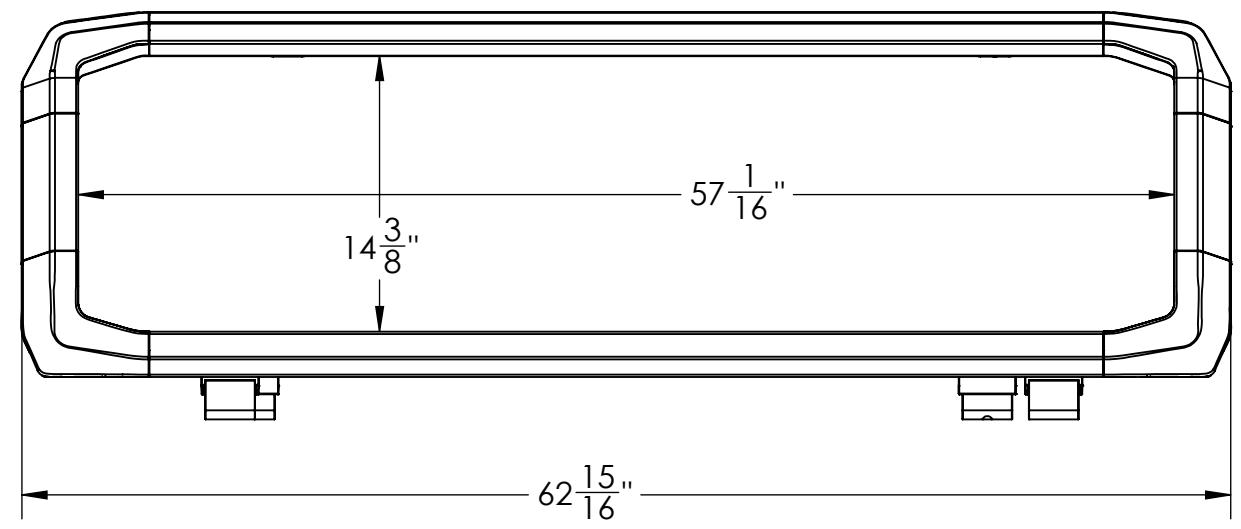

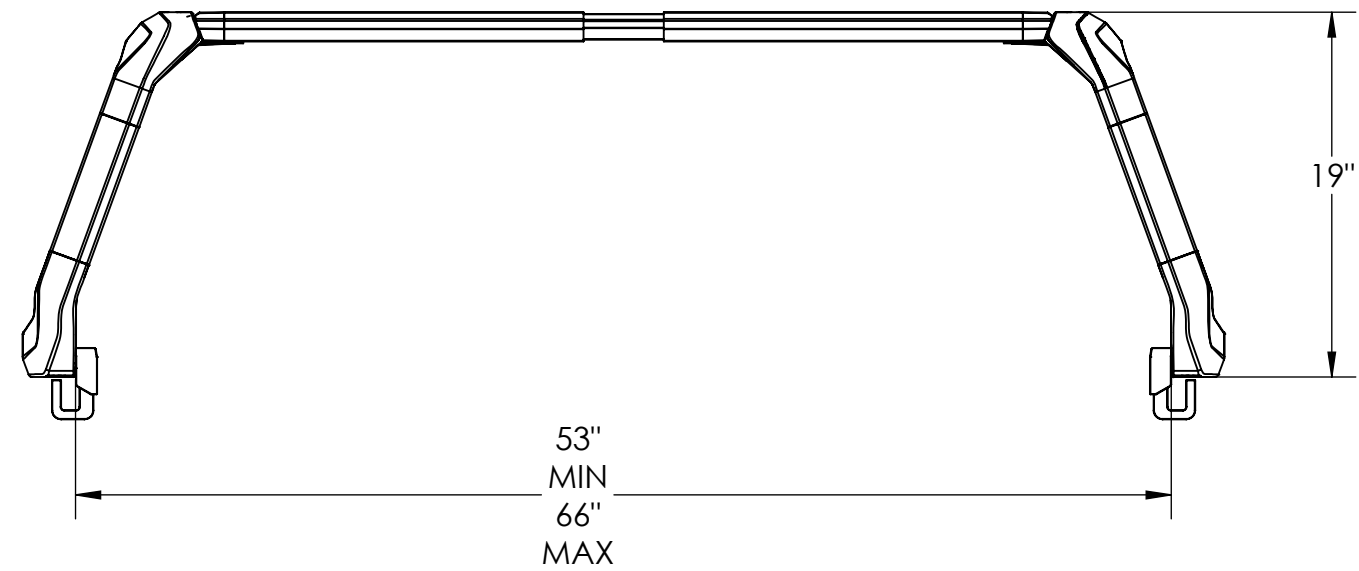
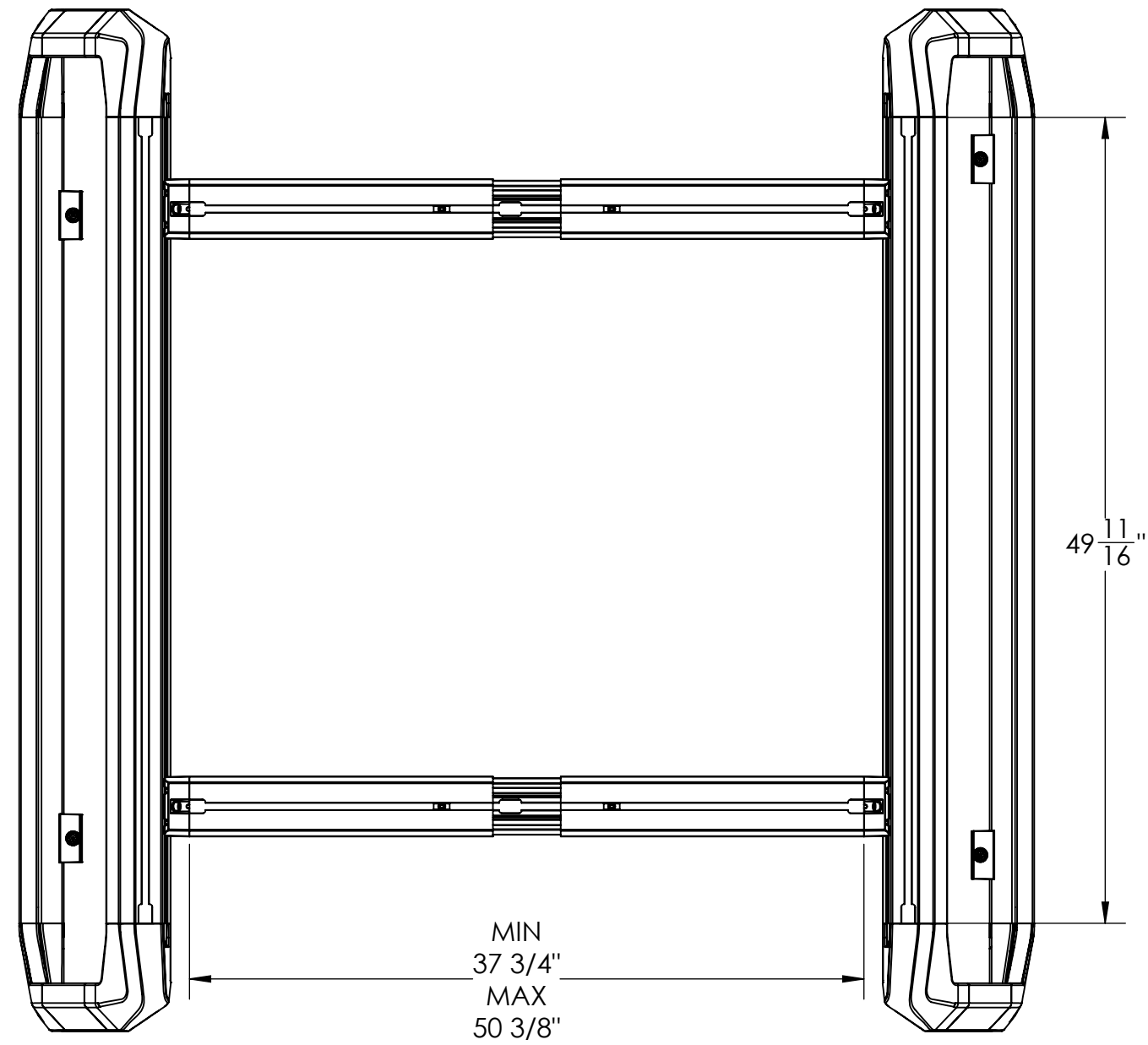
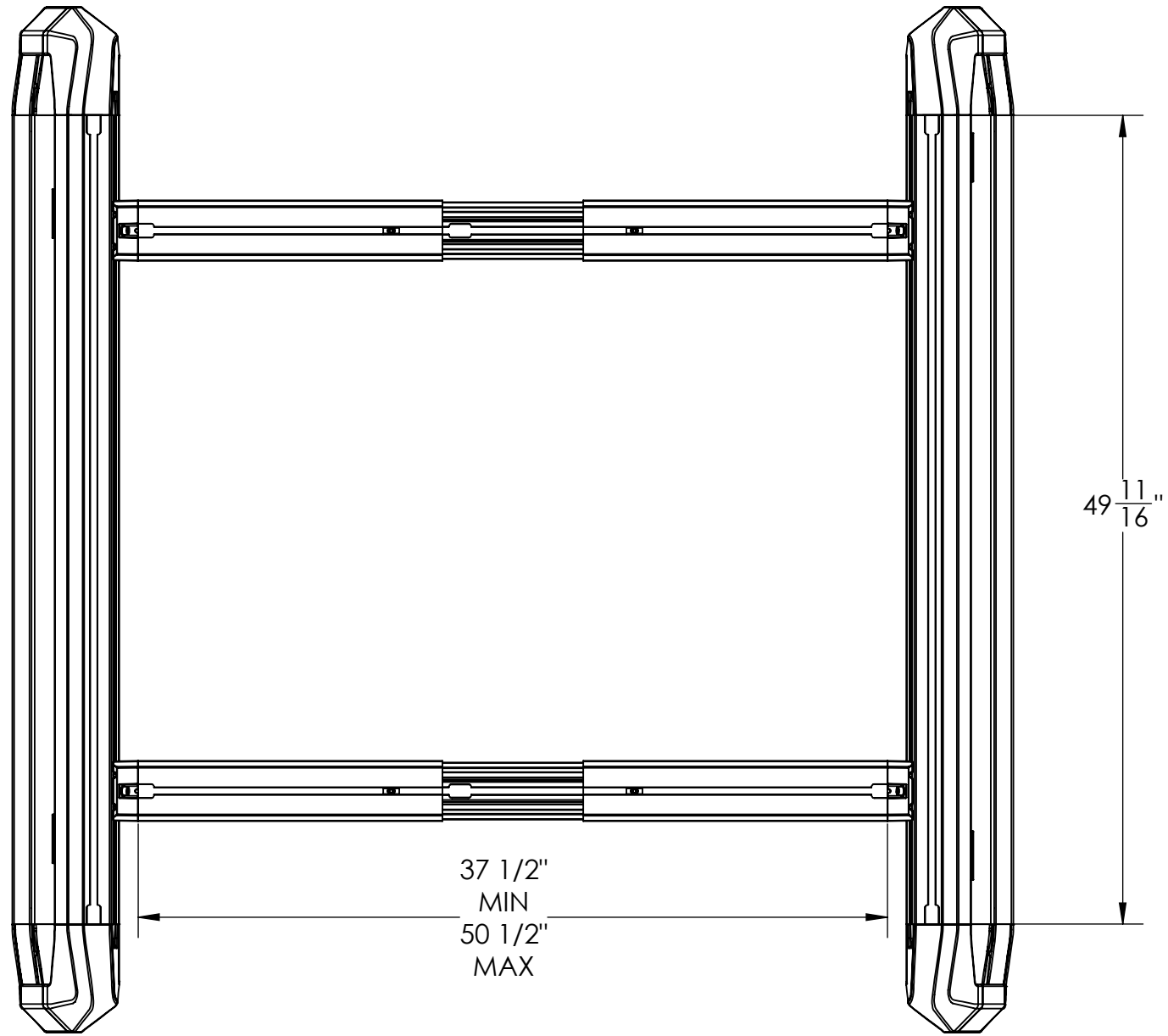

IBEXA2
GLADIATOR

Mid Height Configuration

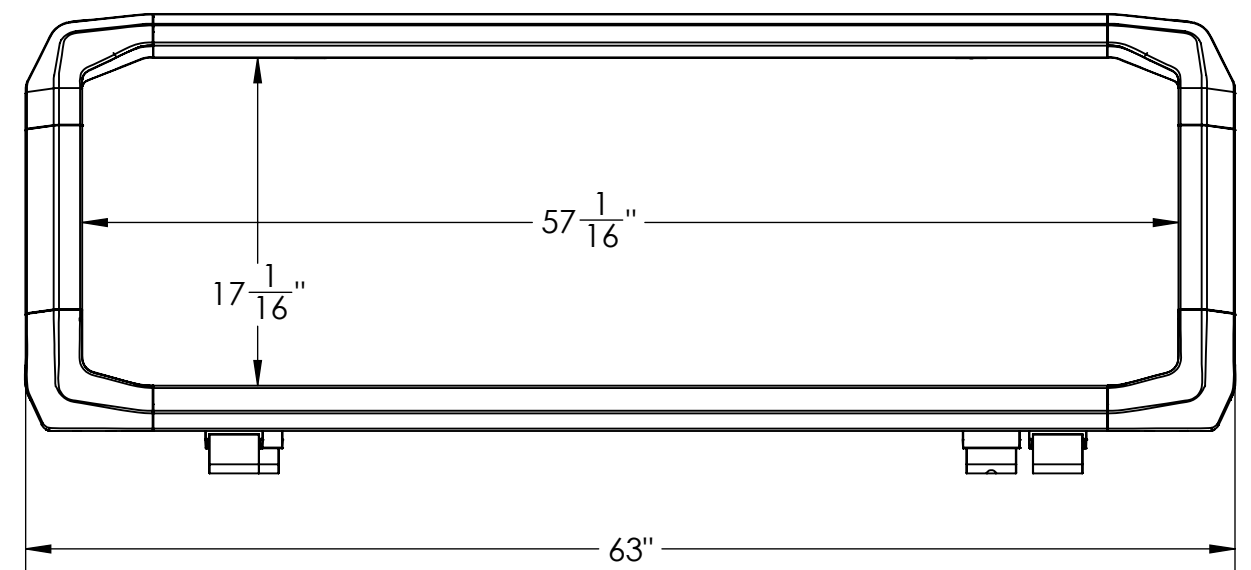
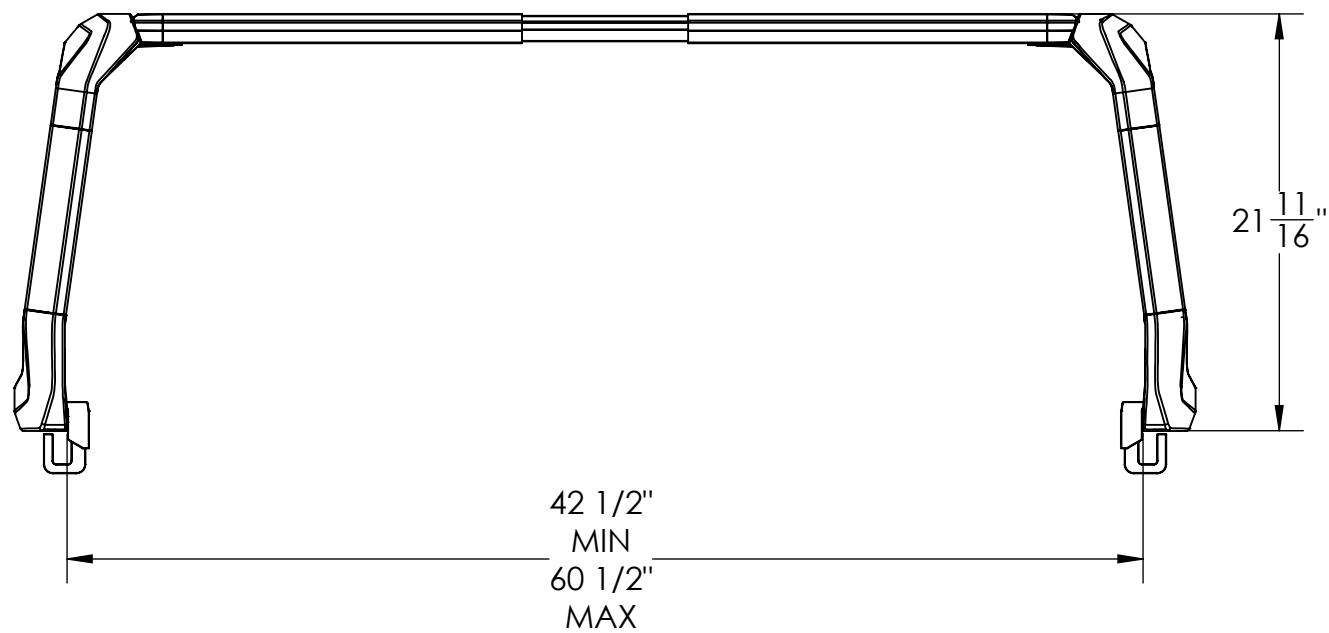
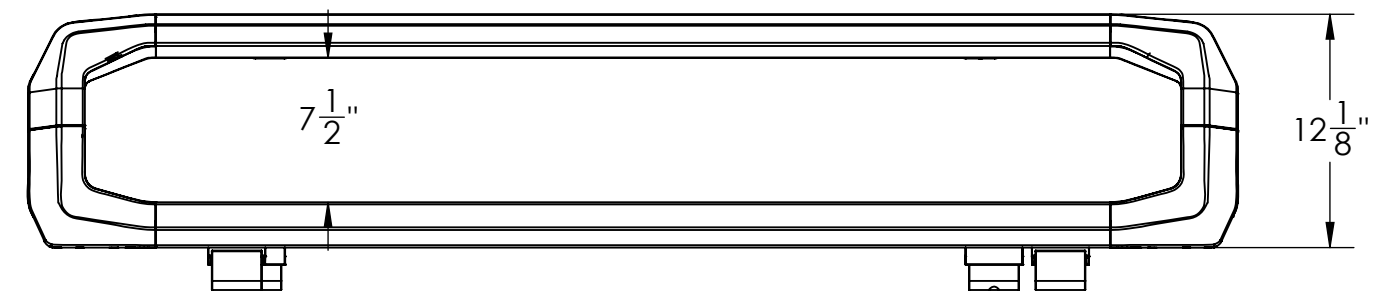

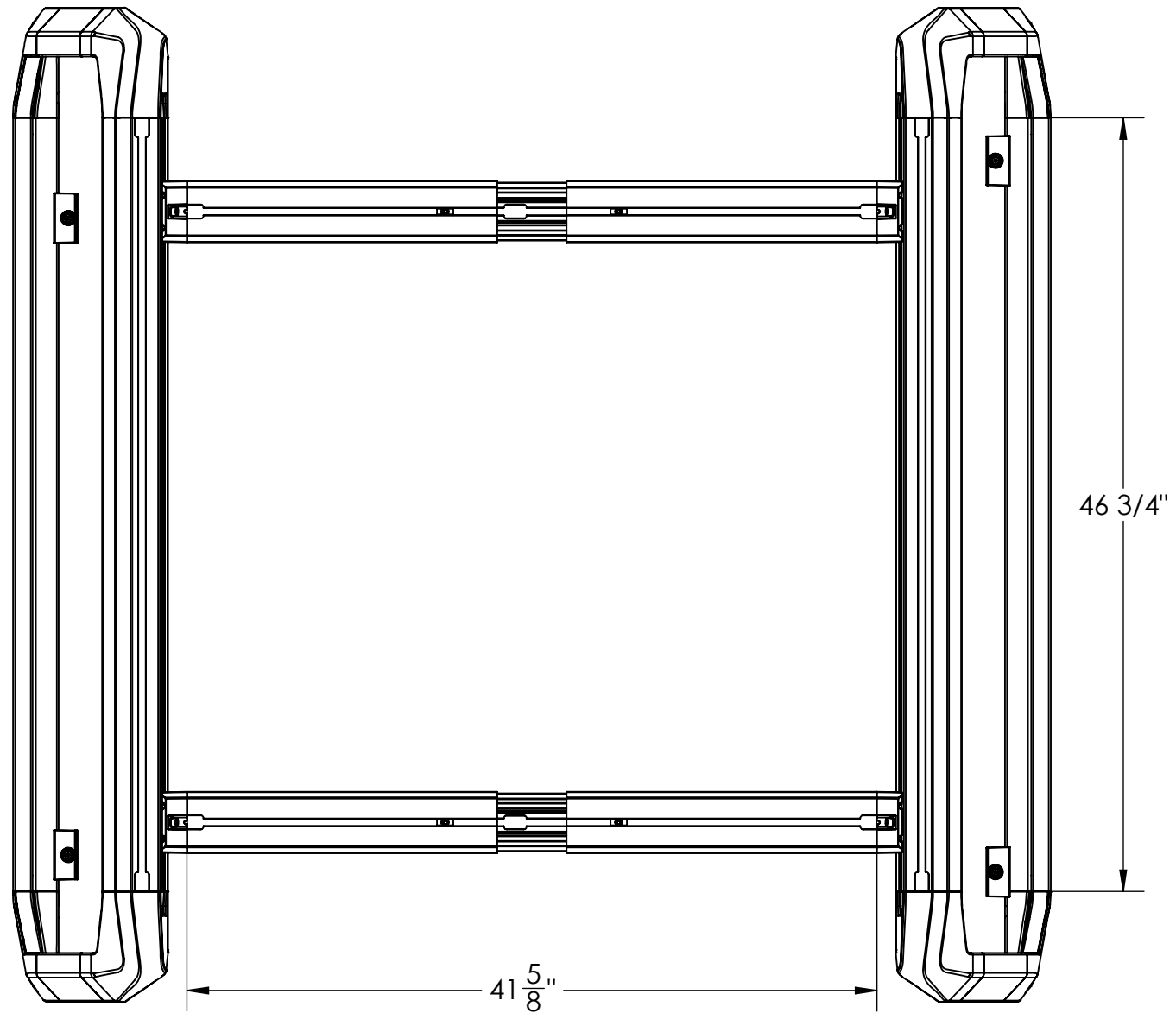

IBEXA3
MID SIZE TRUCK - SHORT BED 2

Mid Height Configuration

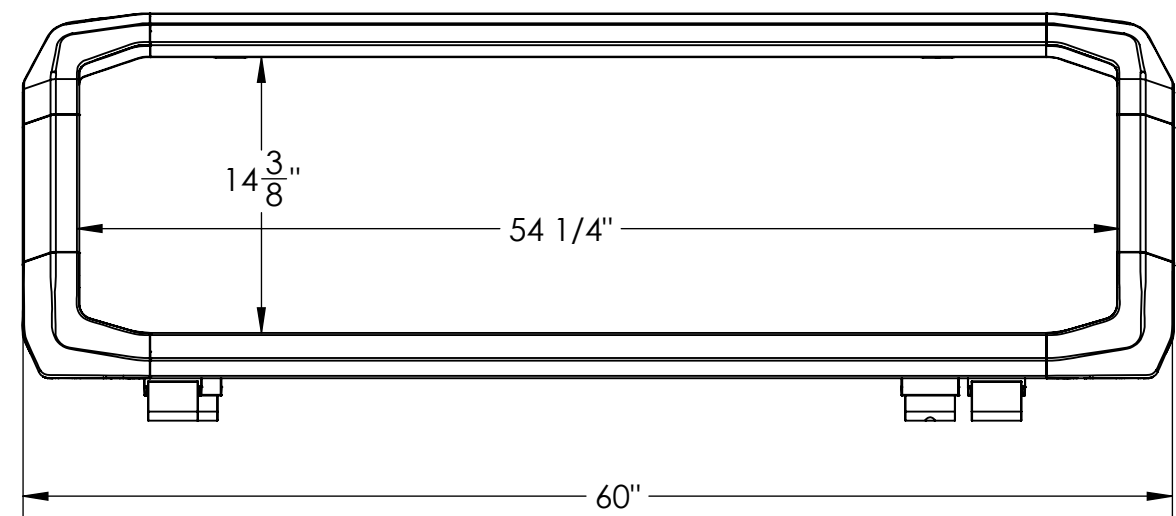
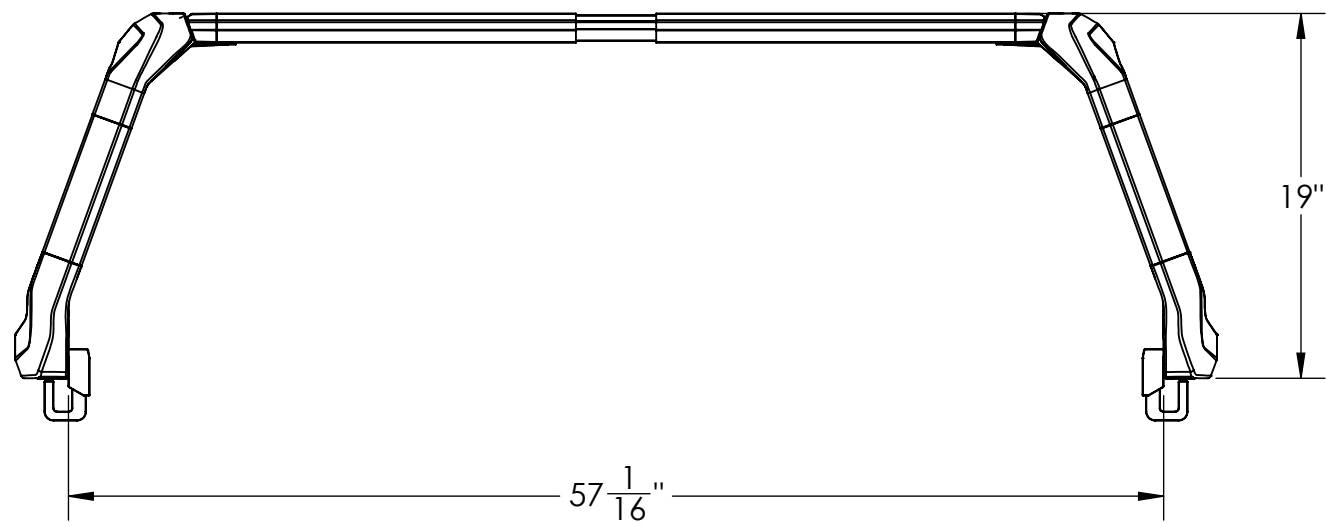
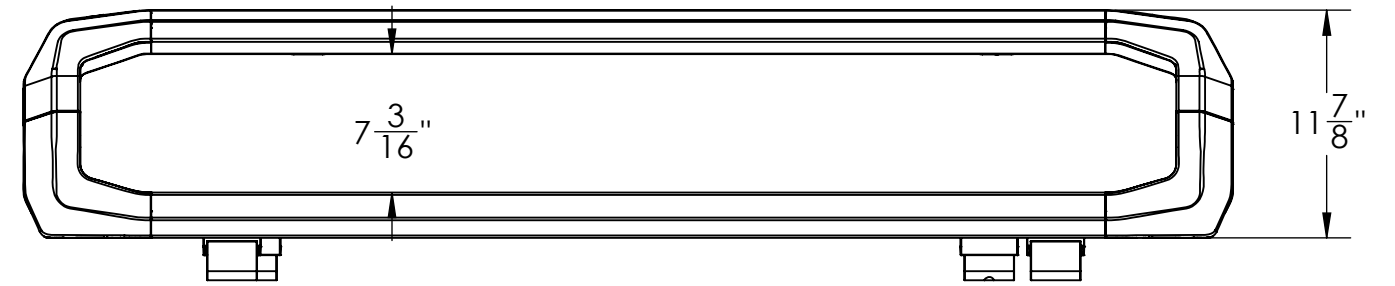

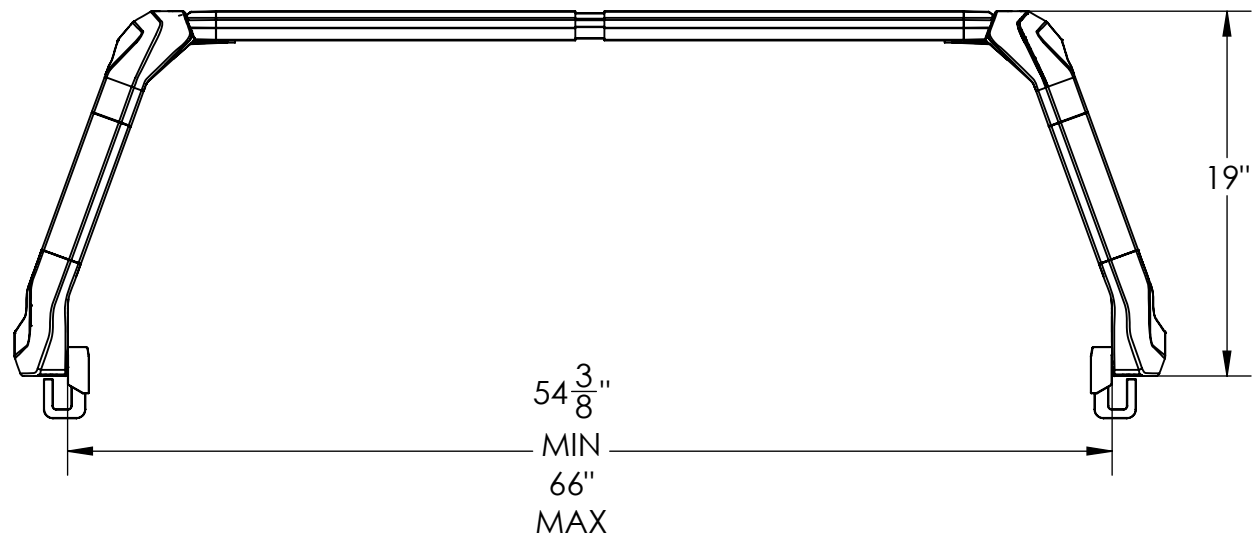
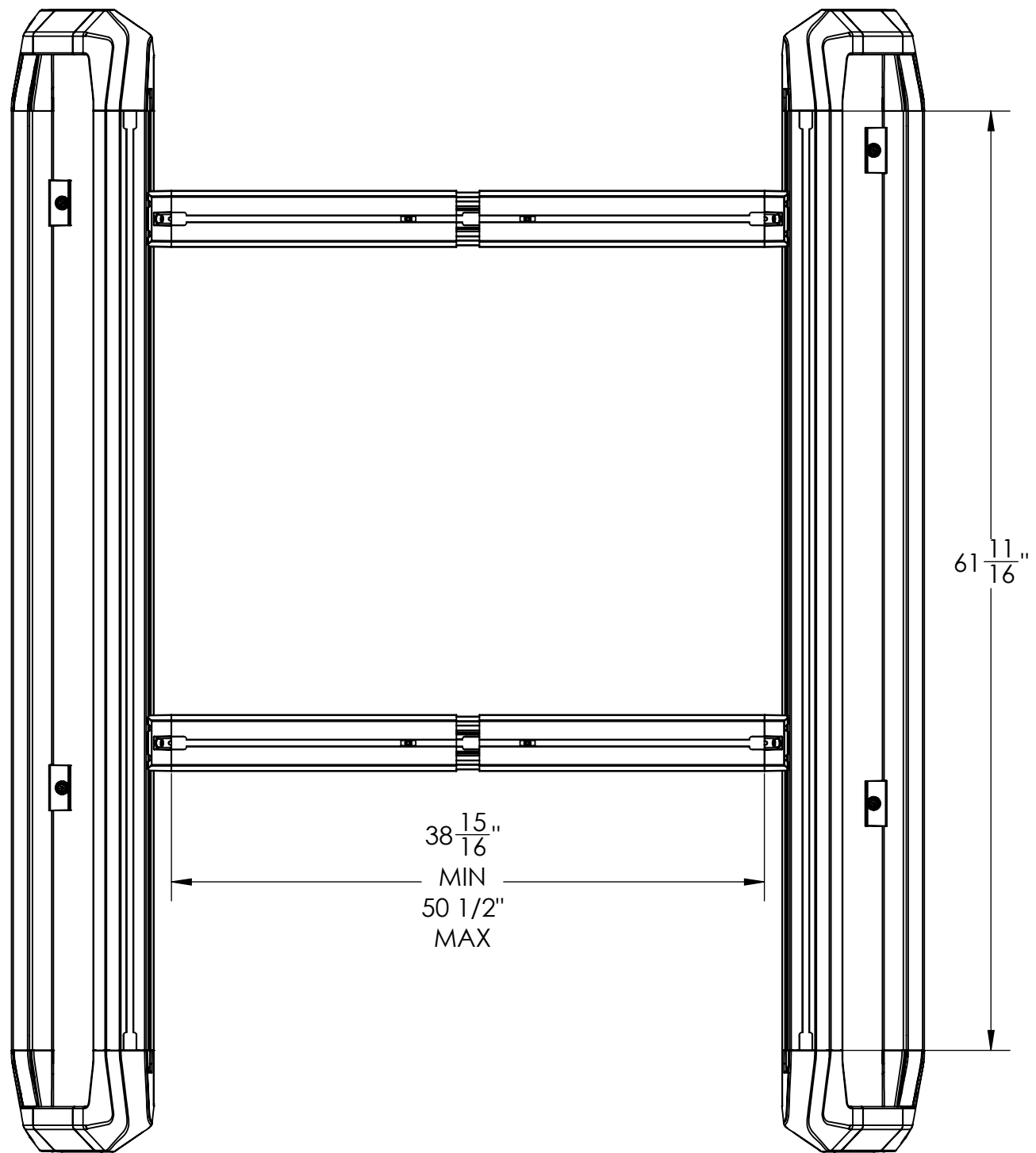

IBEXC1
MID SIZE TRUCK - LONG BED

Mid Height Configuration

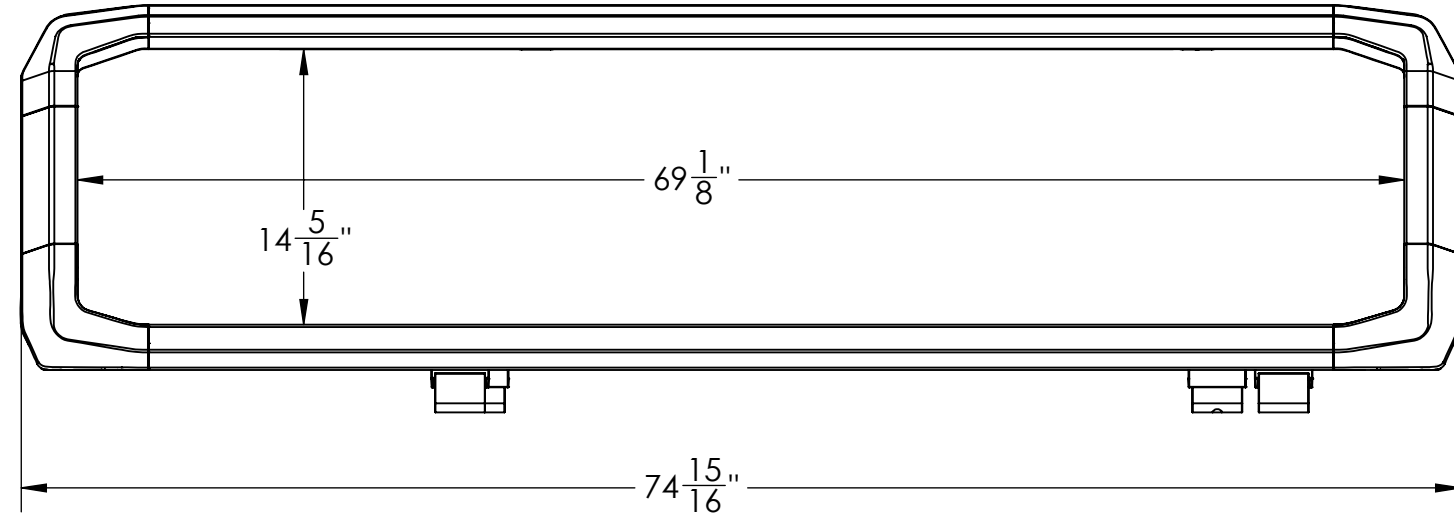
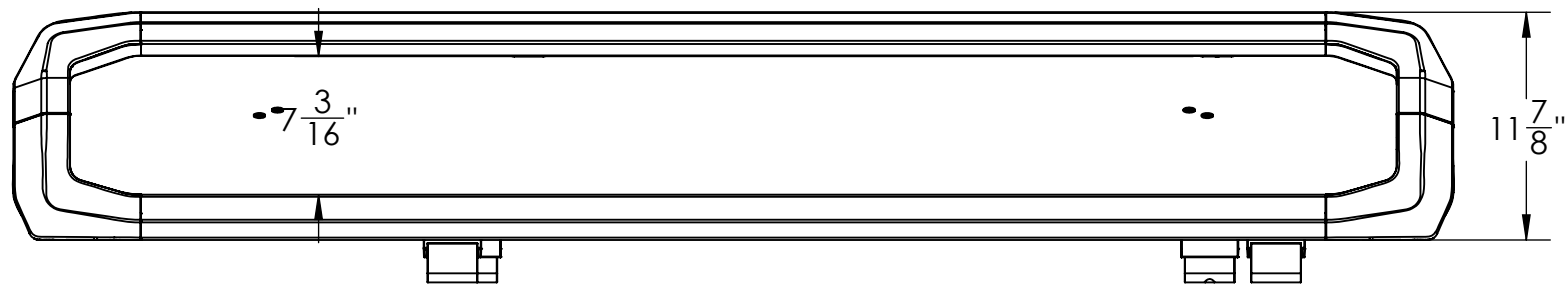

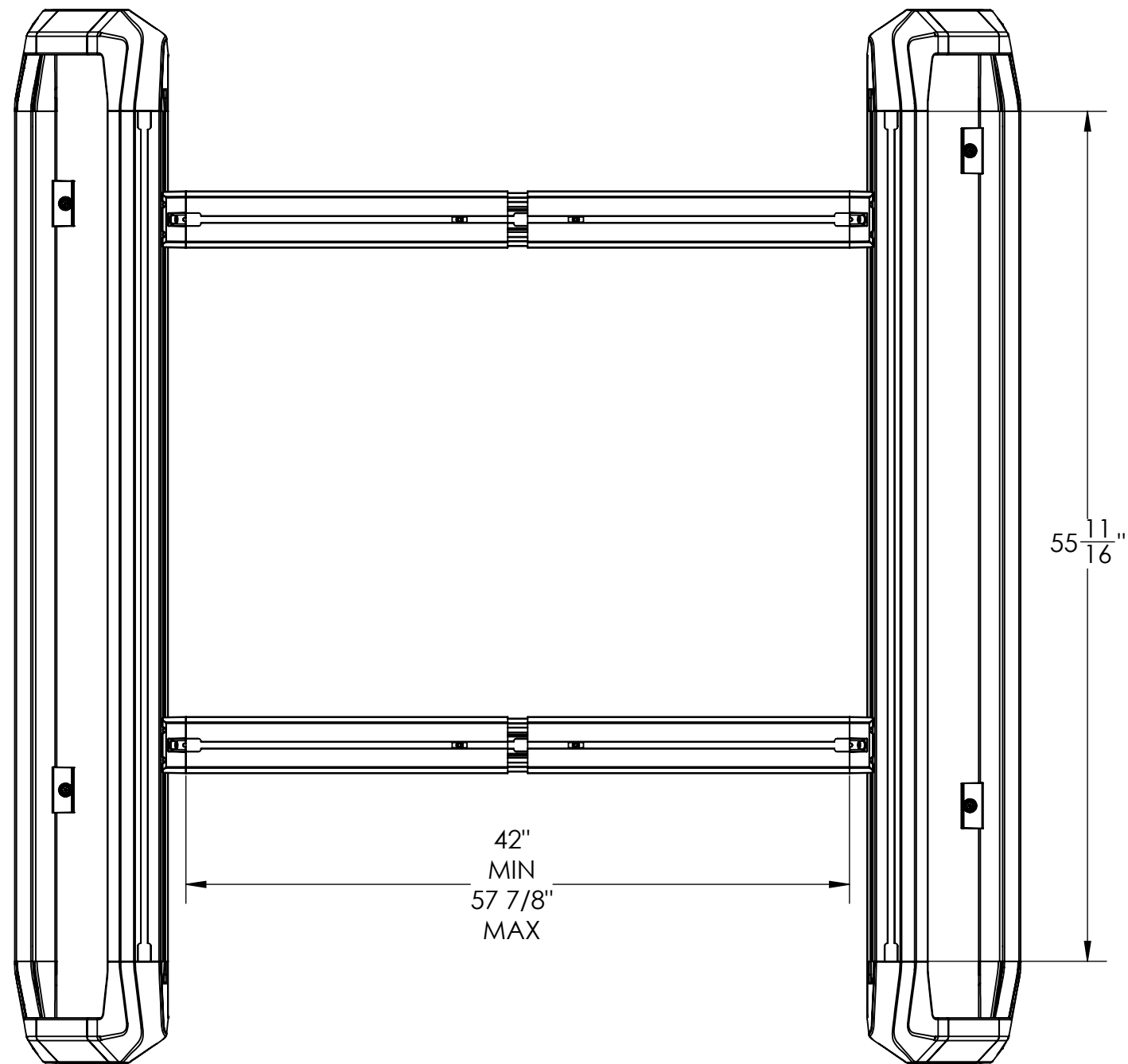

IBEXB2
FULL SIZE TRUCK - SHORT BED

Mid Height Configuration

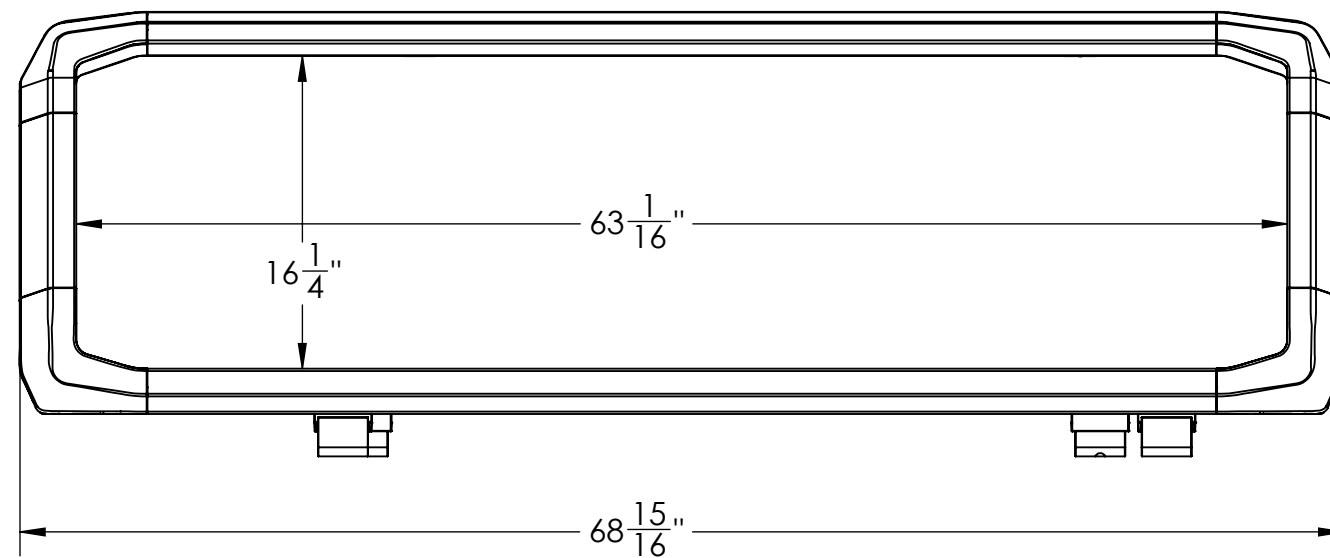
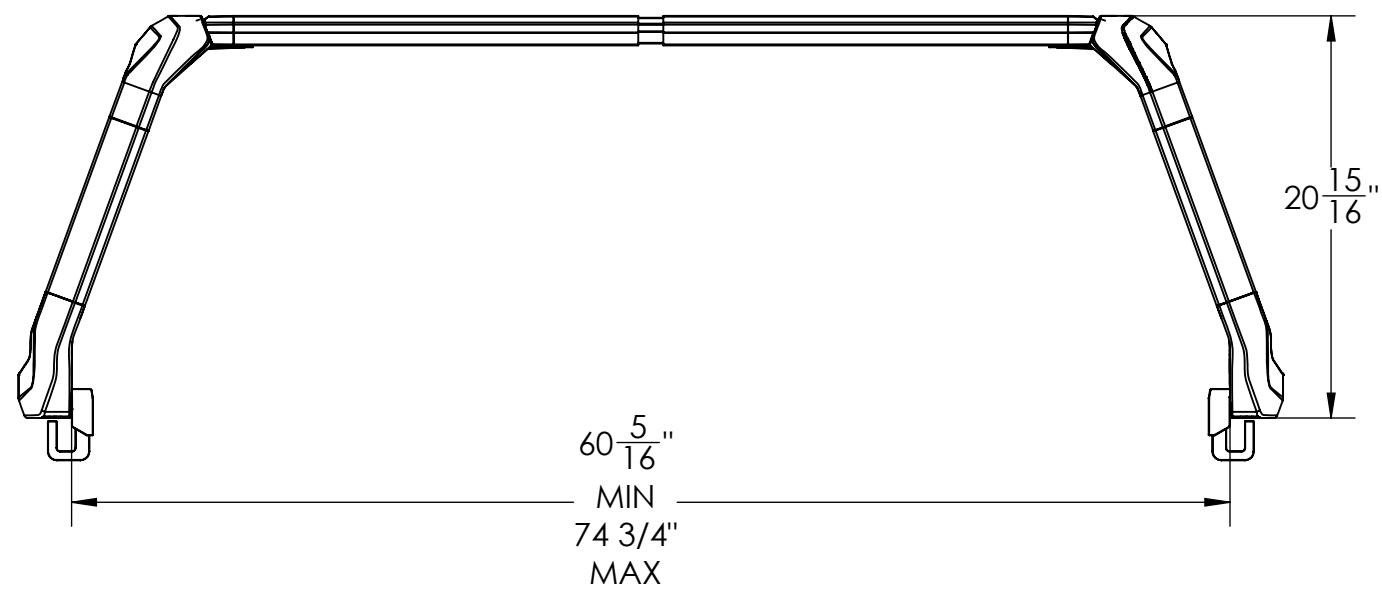
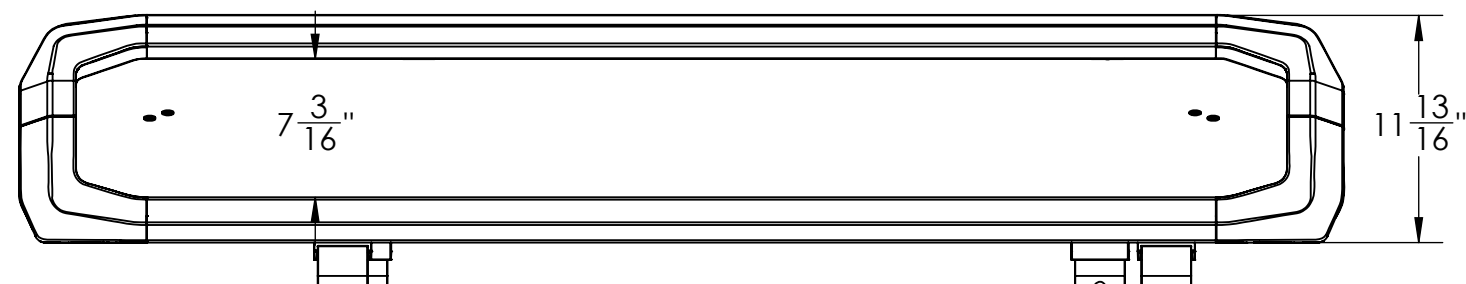

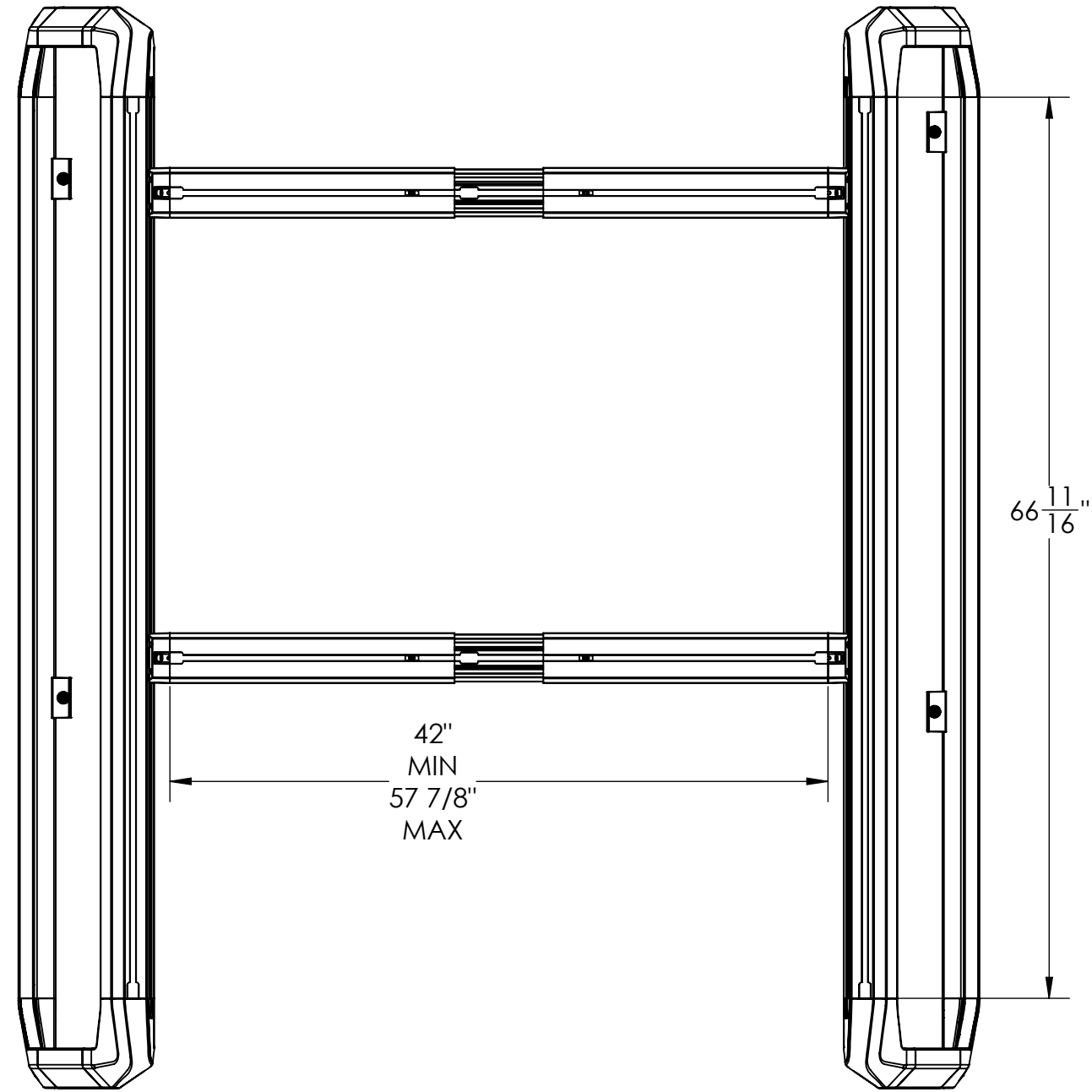

IBEXD2
FULL SIZE TRUCK - MEDIUM BED

Mid Height Configuration

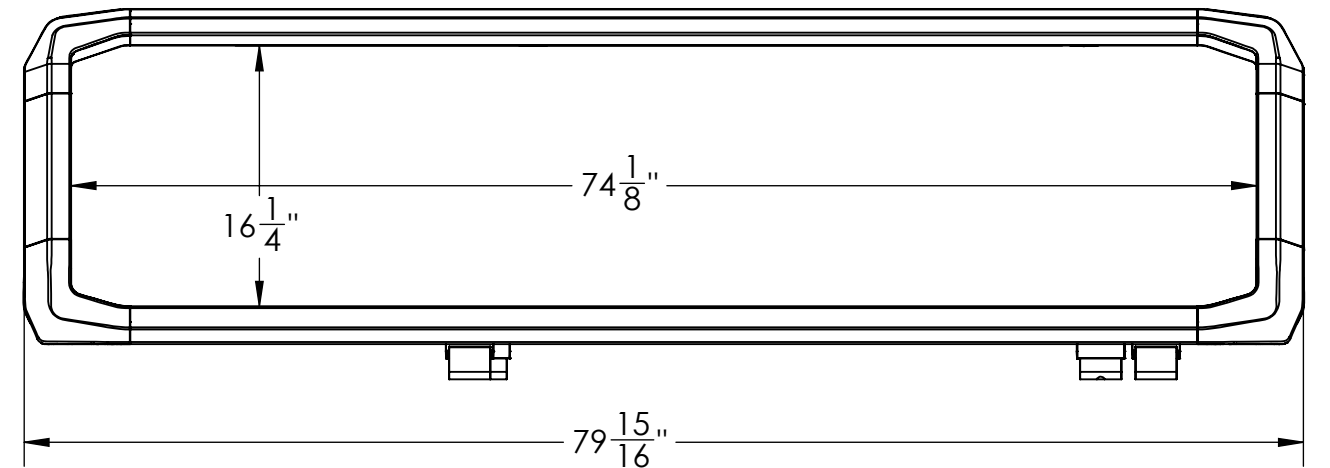
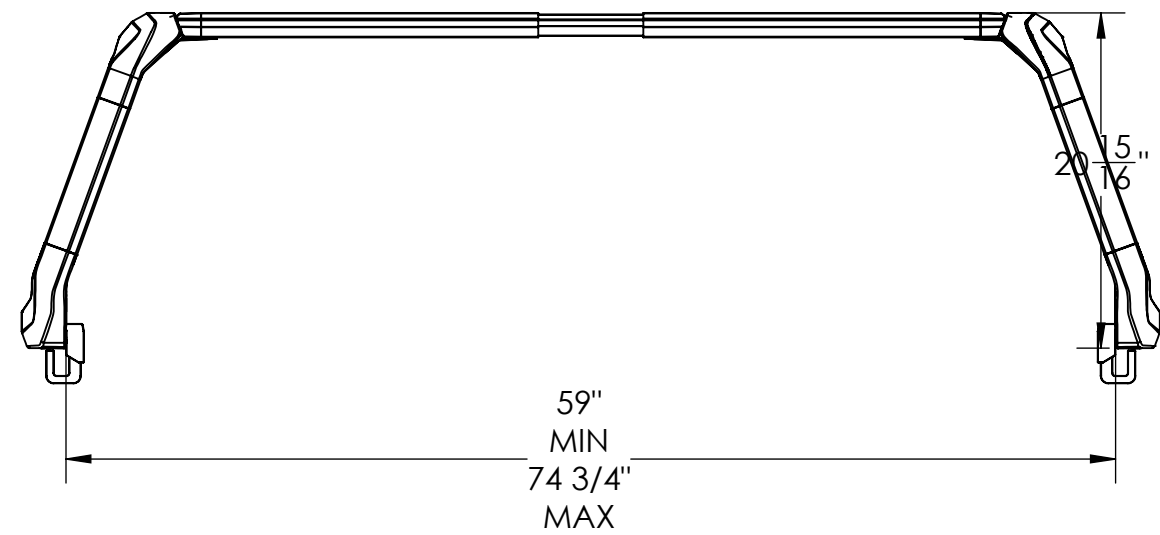
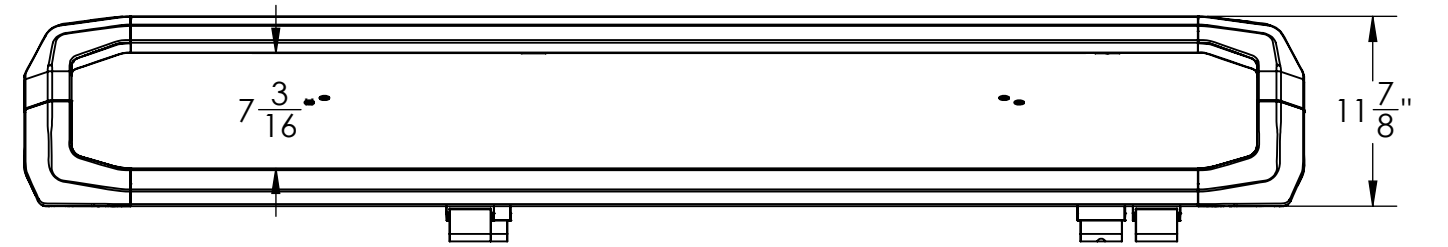

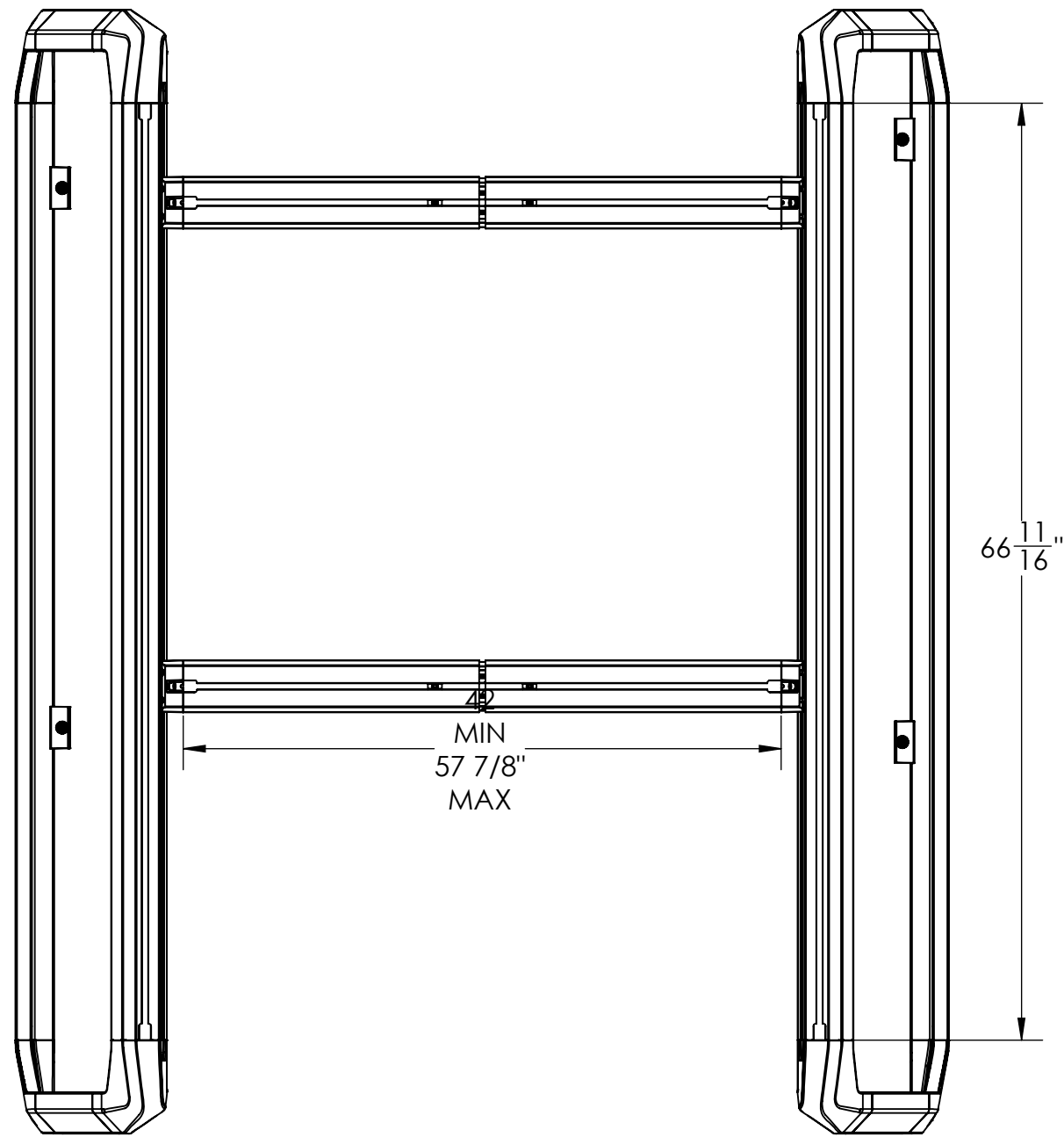

IBEXD3
HEAVY DUTY TRUCK - SHORT BED

Mid Height Configuration

