

# SHERPA™ 2.0

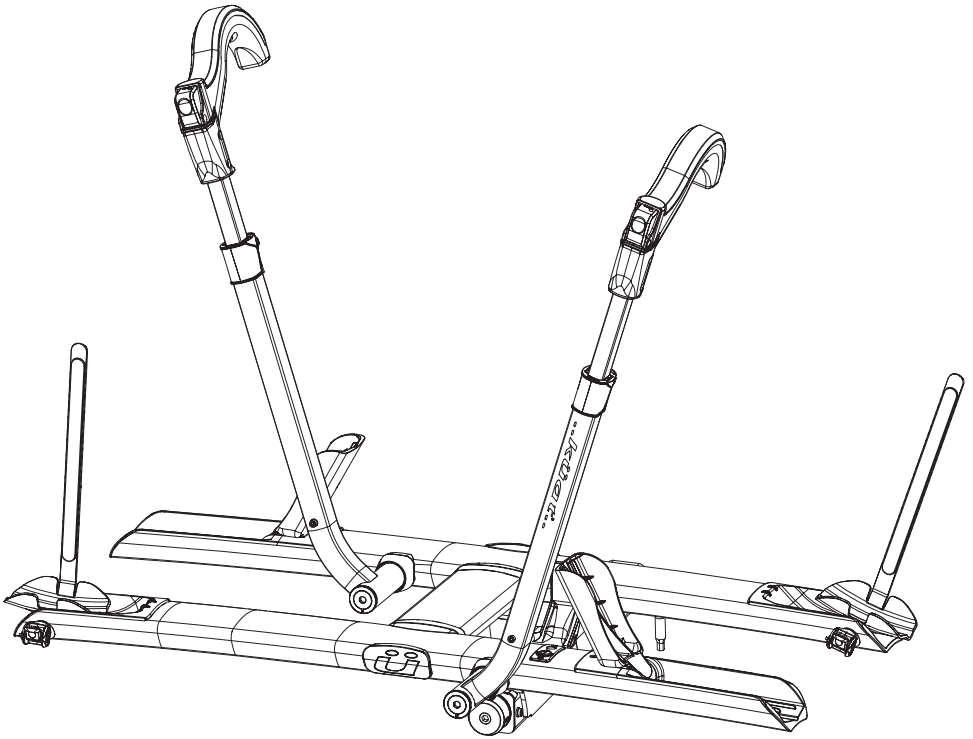

**RACK PACKAGING IS AN ASSEMBLY  
FIXTURE. READ UNBOXING  
INSTRUCTIONS TO EASE ASSEMBLY.**

# Parts:

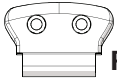

Rear Tray Mount

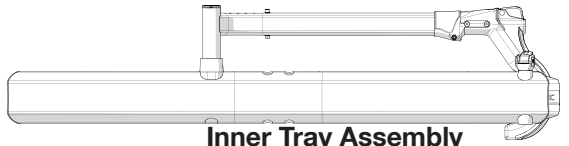

Inner Tray Assembly

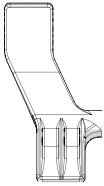

Pivot Handle

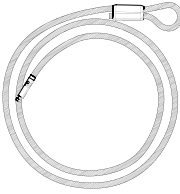

Lock Cable

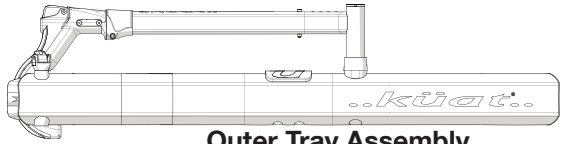

Outer Tray Assembly

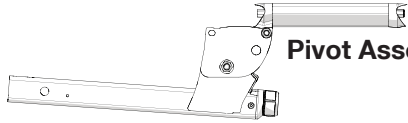

Pivot Assembly

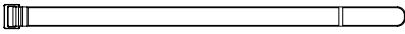

Front Tire Safety Strap



2x M10x450 Bolt with lock washer

## Included in the bag:

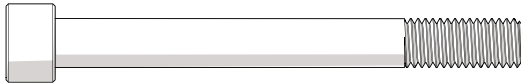

M10x95 Bolt

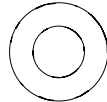

2x M10 Washers

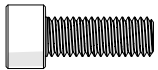

M8x22 Bolt



M8 Lock Washer



M10 Nut



3x Lock Keys  
and Bottle Opener

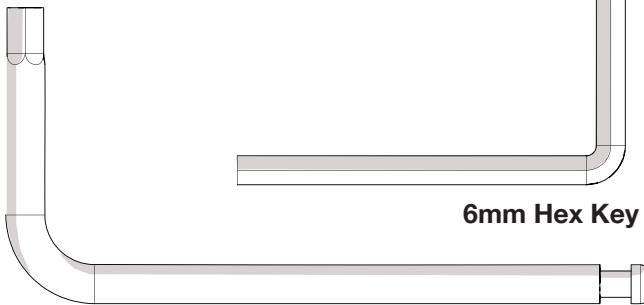

6mm Hex Key

Hitch Pin/8mm Hex Key

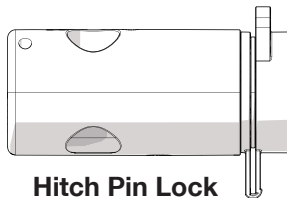

Hitch Pin Lock

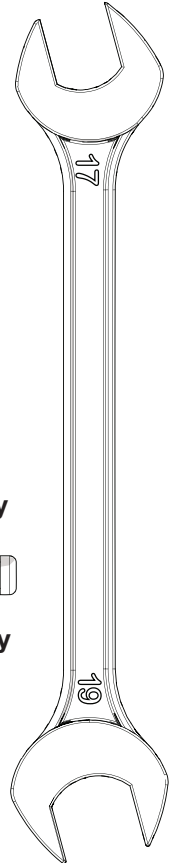

17mm/19mm  
Wrench

# Unpacking and assembly instructions.

**STEP 1. Remove parts box and bracing. Open parts box.**

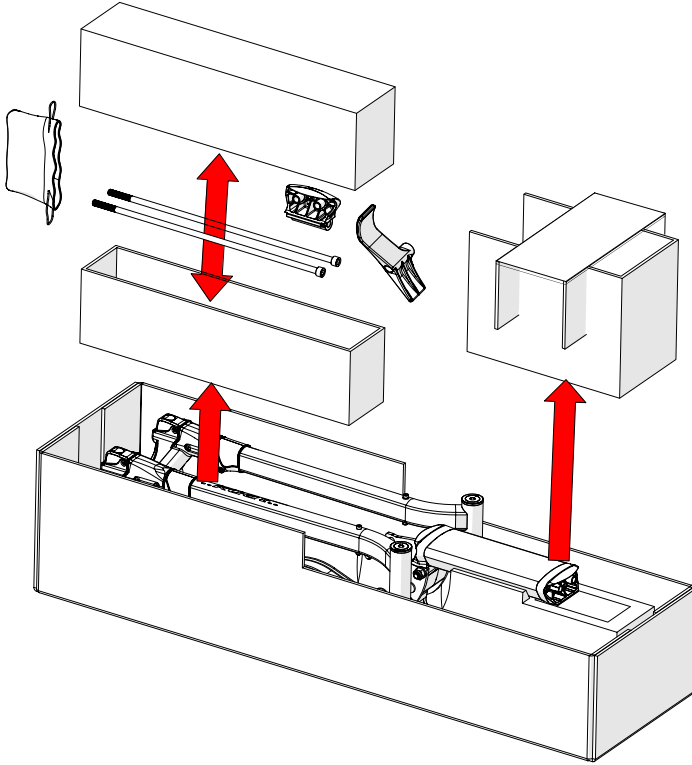

**STEP 2. Remove trays. DO NOT remove hitch assembly.**

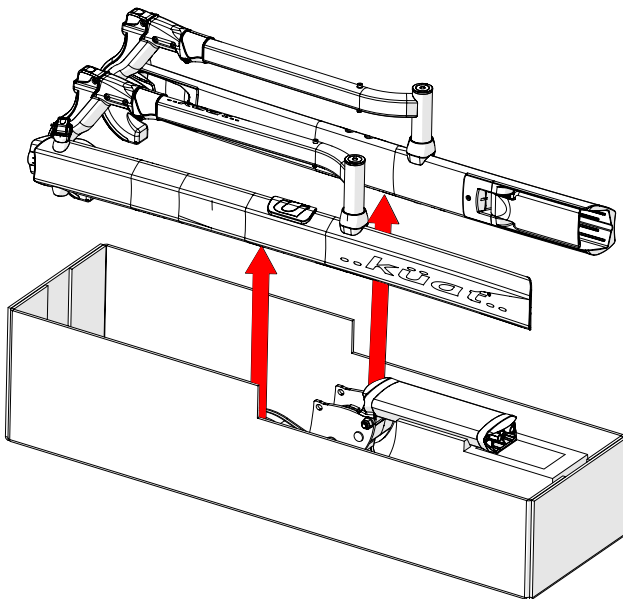

### STEP 3. Place trays into build position.

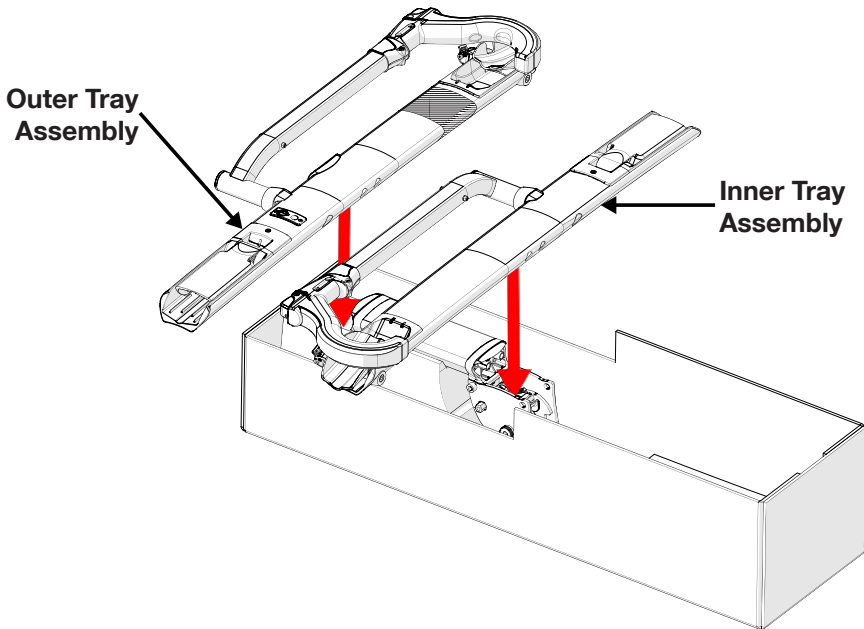

### STEP 4. Assemble trays.

Parts Needed:

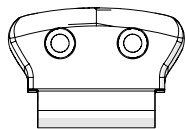

x1 Rear Tray Mount



x2 M10x450 Bolt and Lock Washer

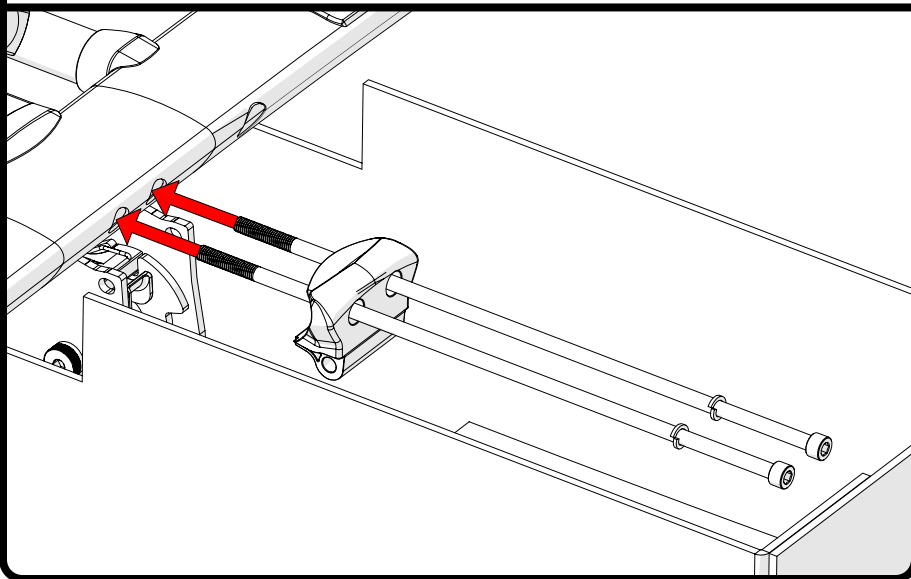



**NOTE:** Tighten to 15ft-lbs(20Nm), alternating bolts between each turn. Excessive tightening will damage the rack.

**AMSO:** Apriete a 20Nm, alternando entre los pernos de cada vuelta. Tightening excesivo puede dañar el bastidor.

**AVIS:** Serrer à 20Nm, en alternance entre les boulons à chaque tour. Tightening excessif endommagerait le rack.

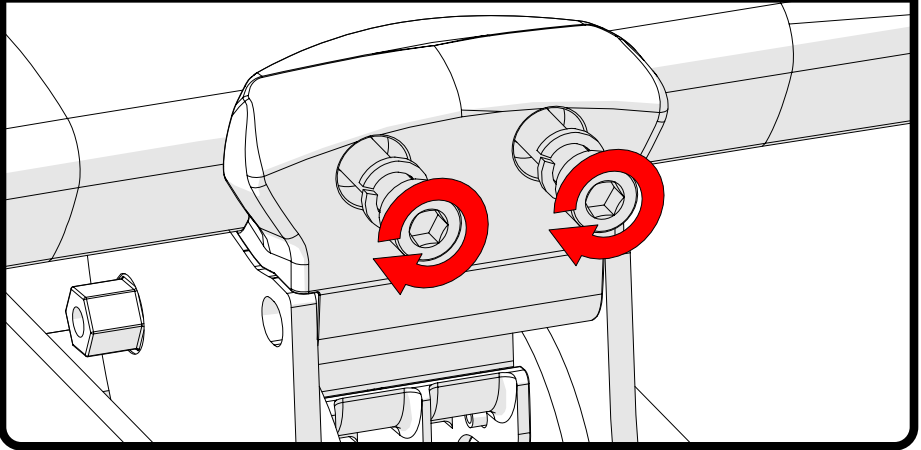

### STEP 5. Install rear tray bolt.

Parts Needed:



x1 M10x95 Bolt

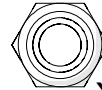

x1 M10 Locknut

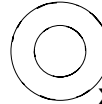

x2 M10 Washer

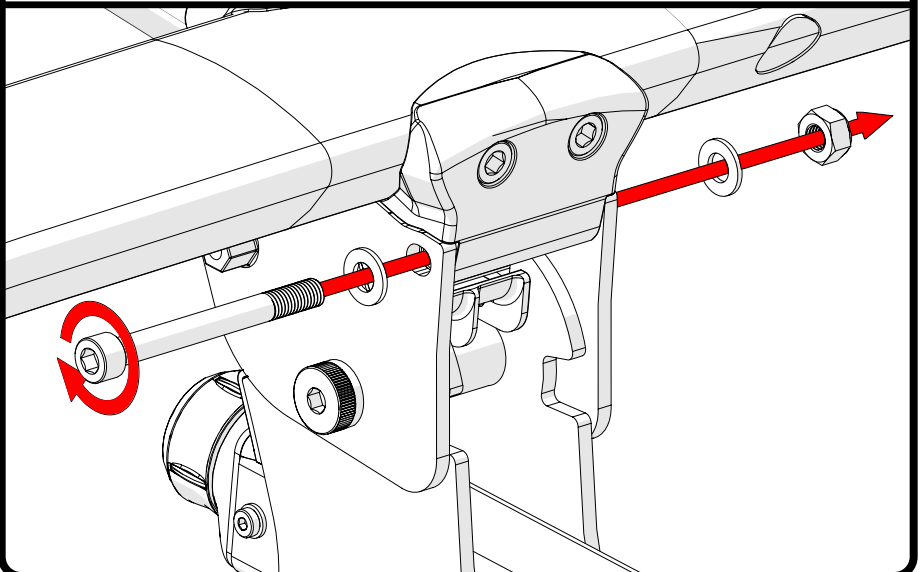

## STEP 6. Install pivot handle.

### Parts Needed:

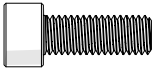

x1 M8x22 Bolt



x1 M8 Lock Washer

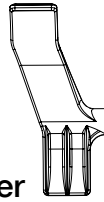

x1 Pivot  
Handle/Pedal

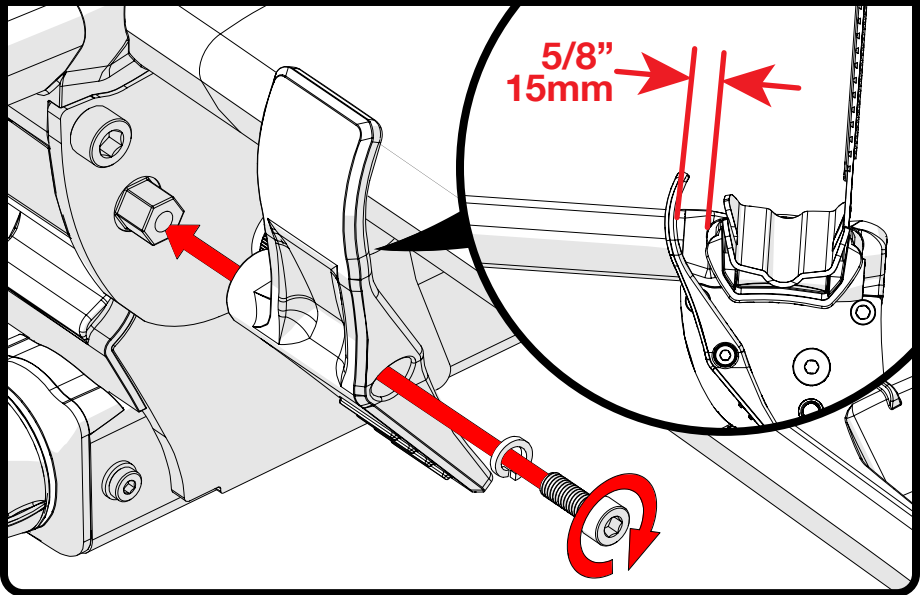

**NOTE:** After first use, check the main tray bolts for loosening, re-tighten if needed. Max 15ft-lbs

**AVISO:** Después del primer uso, compruebe las principales pernos bandeja por aflojamiento, vuelva a apretar si es necesario. Max 20Nm

**AVIS:** Après la première utilisation, vérifiez les boulons principaux de plateau pour descellement, resserrer si nécessaire. Max 20Nm

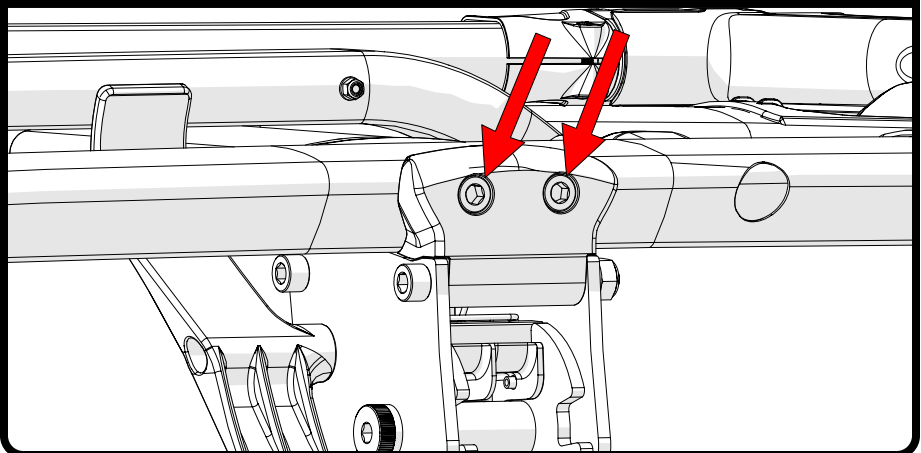

# Installation instructions.

## STEP 1. Install into hitch receiver.

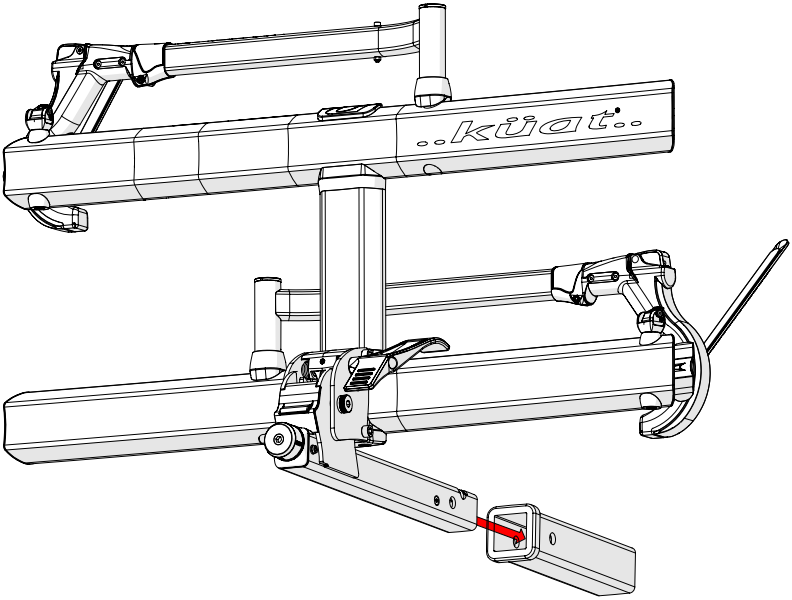

## STEP 2. Attach the locking hitch pin. Turn the knob to tighten the hitch cam.

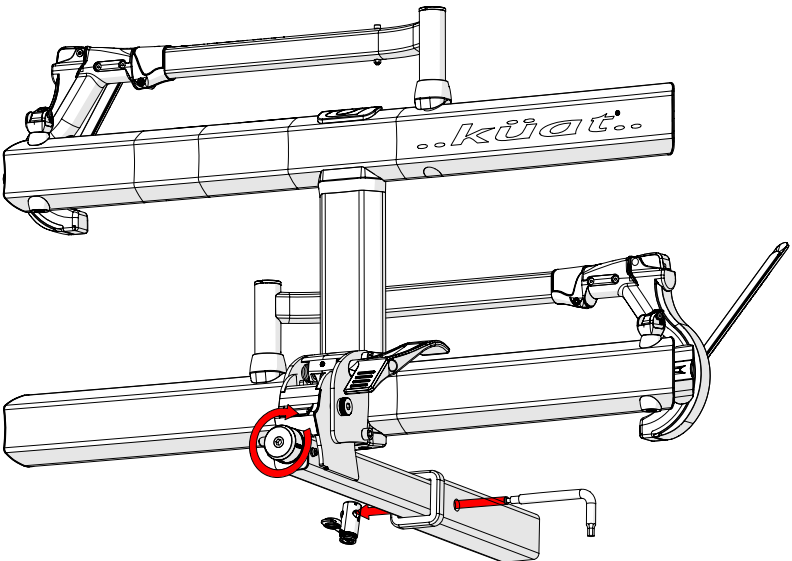

# Loading bicycles.

**STEP 1.** Pivot the tray assembly down, using the pivot handle to release the tray.

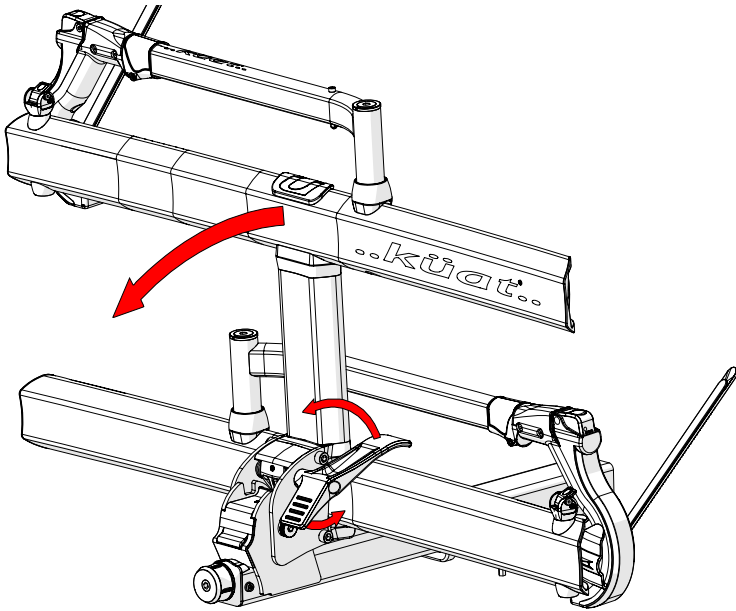

**STEP 2.** Open the front tire cradles.

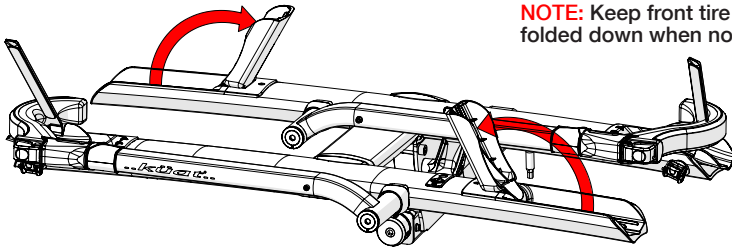

**NOTE:** Keep front tire cradles folded down when not in use.

**STEP 3.** Fold out the front tire hooks.

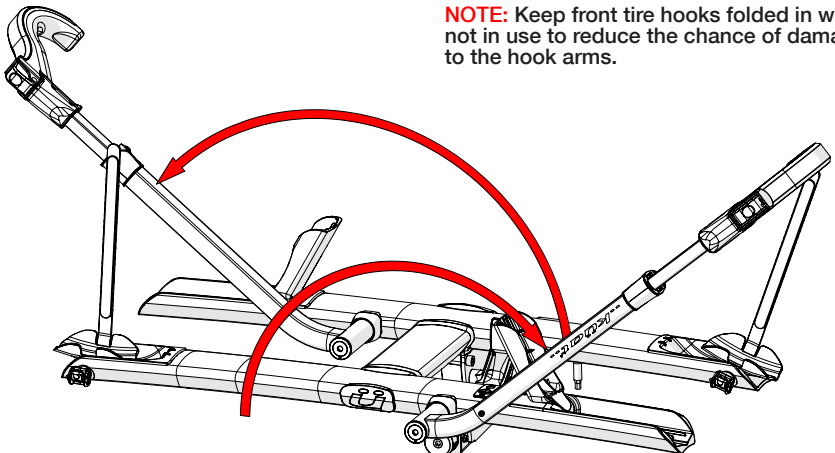

**NOTE:** Keep front tire hooks folded in when not in use to reduce the chance of damage to the hook arms.

**STEP 4.** Position the front tire hook against the tire and as close to the fork as possible.

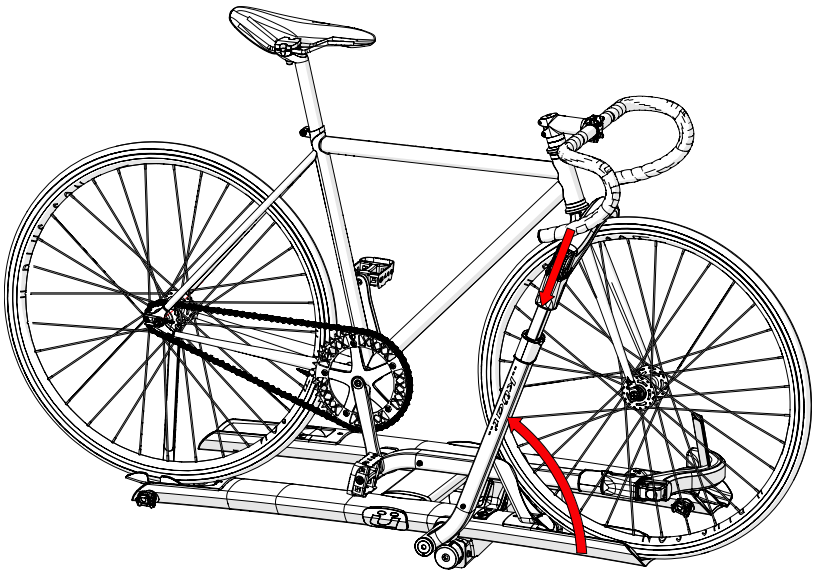

**NOTE:** Proper placement of the tire hook is critical to securing the bicycle to the rack. The tire hook should be as close to the fork as possible.

**AVISO:** La colocación correcta del gancho de los neumáticos es fundamental para asegurar la bicicleta al bastidor. El gancho de los neumáticos debe ser lo más cerca del tenedor posible.

**AVIS:** Le positionnement correct du crochet des pneus est essentielle pour assurer la bicyclette à la crémaillère. Le crochet de pneu doit être aussi proche de la fourche que possible.

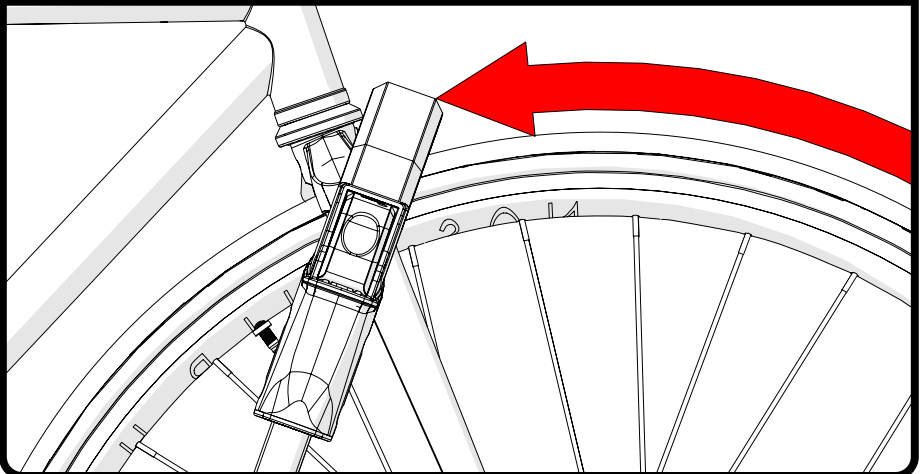

**STEP 5.** Ensure rear bicycle tire is properly seated in the rear cradle. Feed strap through ratchet pawl and pull strap down to tighten.

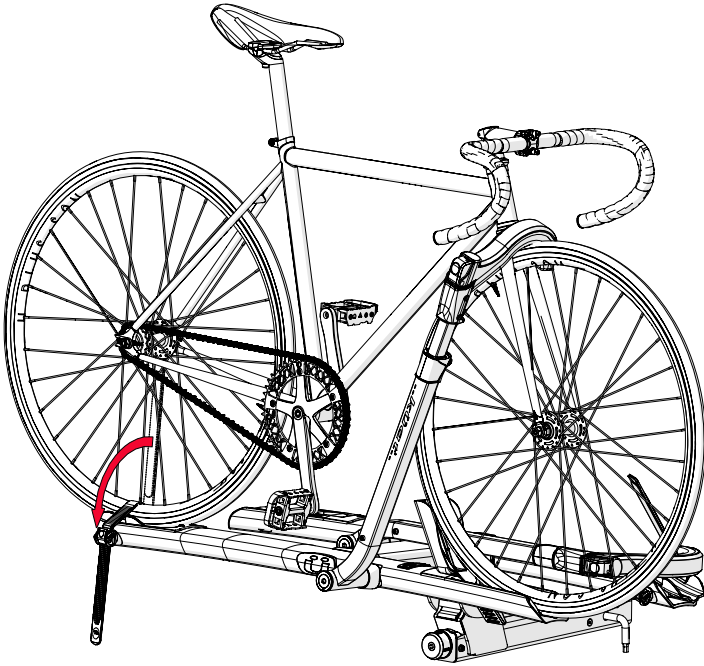

**NOTE:** When loading bicycles with 20"-24" front tires an adapter must be used. Please contact Kuat Racks directly by calling toll free 1(877)822-5828, or by emailing us at [info@kuatracks.com](mailto:info@kuatracks.com) and a 20"-24" adapter kit will be provided.

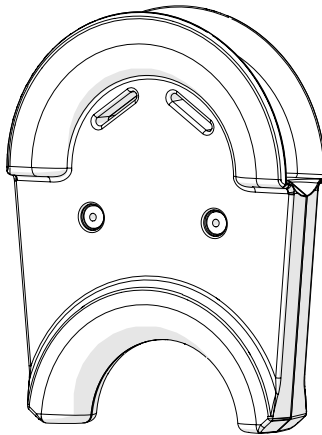

**20"-24" Adapter Kit**

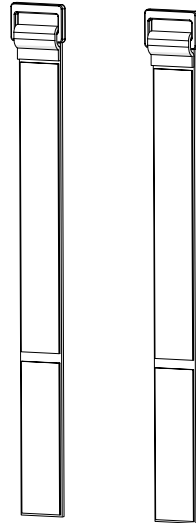

**NOTE:** Front Tire Safety Strap must be used for bicycles with tires larger than 2.35" or a wheelbase longer than 45".

**AVISO:** Neumático delantero correa de seguridad debe ser utilizado con las bicicletas con neumáticos más grandes de 6cm o una distancia ente ejes más largo que 114cm.

**AVIS :** Front Tire Sangle de sécurité doit être utilisé avec des bicyclettes avec des pneus plus larges que 6cm ou un empattement plus long de 114cm

**PARTS NEEDED:**

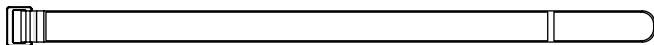

x1 Front Tire Safety Strap

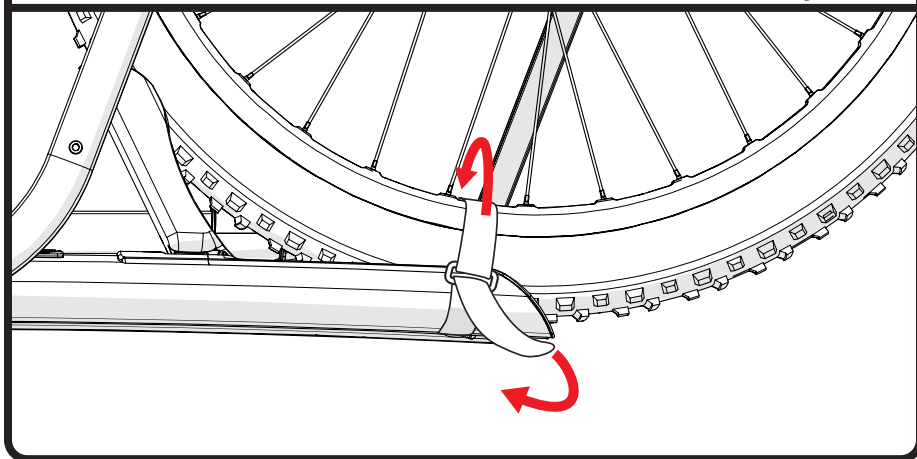

**NOTE:** If the Front Tire Safety Strap is used in conjunction with a smaller, shorter bicycle, the Front Tire Hook may be placed away from the fork up to 1" (25mm). Caution must always be taken to ensure each bicycle is secured on the rack before any travel.

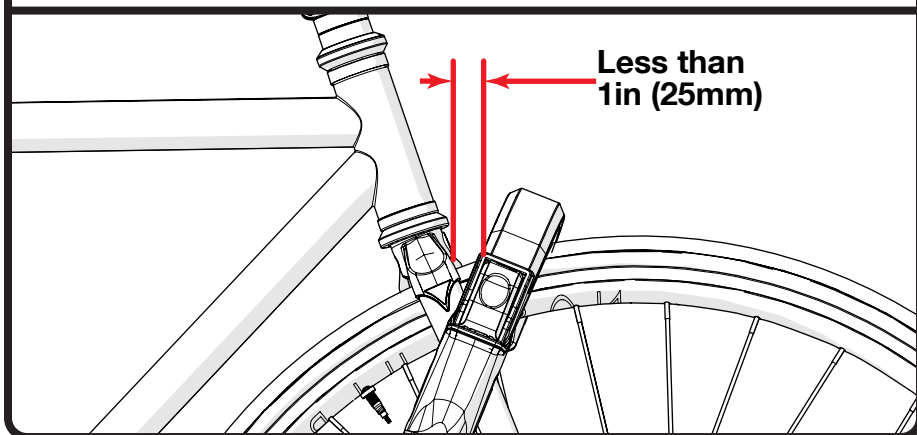

## Additional Notes.

### Locking bicycles.

Loop the lock cable around the frame(s) and insert the latch tip into the lock on the outside tray.

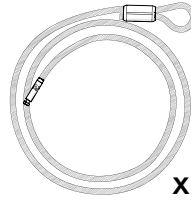

Parts  
Needed:

x1 Lock Cable

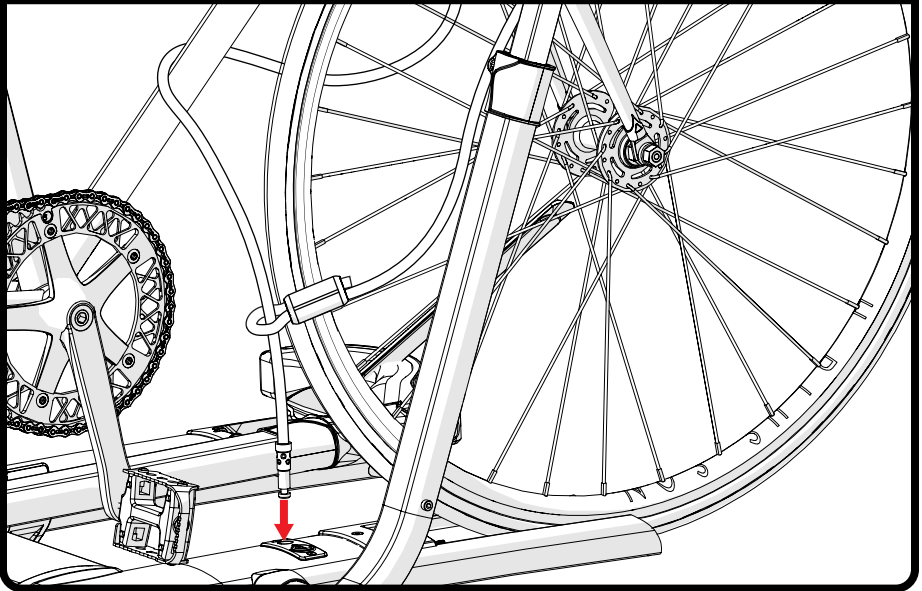

**NOTE:** With the tire hooks folded down, the tire hook next to the pivot handle can be used to gain leverage over the pivot handle making it easier to disengage the pivot.

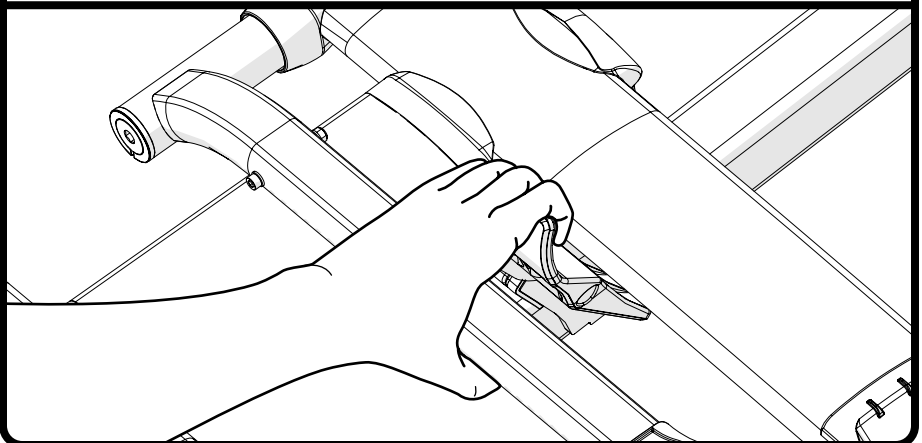



**NOTE:** The rack can be tilted away providing additional clearance for trunk or rear hatch access.

**AVIS:** Le rack peut être incliné loin fournissant jeu supplément pour le tronc ou l'accès de hayon.

**AVISO:** El bastidor se puede inclinar de distancia proporcionando despacho adicional para el tronc o el acceso escotilla trasera.

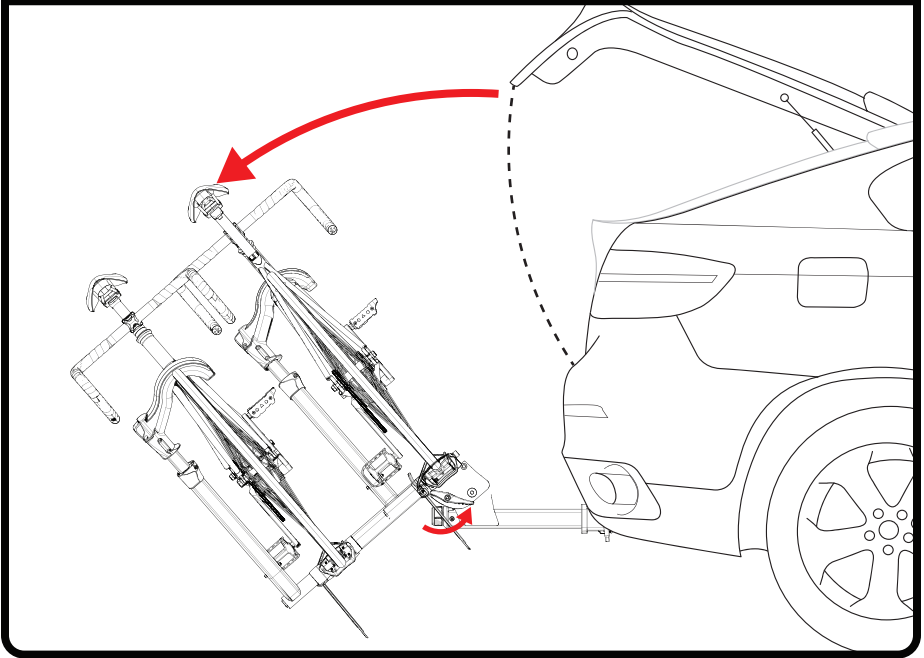

## Tips and Tricks.

- Periodically check all nuts and bolts for proper tightness, not doing so can lead to premature wear or rack failure.
- Lubricate the lock mechanisms using a light oil. Keep the cover on the hitch pin lock at all times.
- The 8mm hex key on the hitch pin can be used to tighten and loosen the cam system.
- Keeping your rack clean will help prevent corrosion and keep the rack working correctly for years.
- The pivot handle is also designed to be used as foot pedal when lowering the trays.
- Make sure the bicycles' tires are properly inflated and free of leaks. Bicycles can become loose if a tire deflates while in the rack.

# Küat Rack Warnings

## SHERPA™ 2.0

Number Of Bikes

2

Weight Per Bike

40 lb

18.2 kg

Max Wheelbase

47 in

1194 mm

Max Tire Width

2.75 in

70 mm

### Küat No Worries Warranty

Our “No Worries Warranty” has you covered like the poncho in your backpack or the winch on your bumper, there when you need it. The goal? To ensure your Küat product performs as intended, over time, every time, for life.

### WARNINGS

- Follow instructions for proper assembly, mounting and loading procedures.
- Check tightness of all bolts and screws periodically.
- Make sure the rack and your vehicle receiver are in good working condition before each use.
- Do not use rack off-road.
- Do not use hitch extenders with this product.
- Do not use this product on a recreational vehicle or trailer.
- Do not use rain or wind-covers or tarps with this product.
- Place the front tire clamp next to the front fork.
- Do not take through automatic carwash.
- Do not use front tire bicycle fenders with this product.
- Use included safety strap for front tire on bikes with a wheelbase over 45” and/or a tire width of over 2.35”.

If you have questions or problems with your rack, please contact Küat Racks directly by calling toll free 1(877)822-KUAT, or by email: [info@kuatracks.com](mailto:info@kuatracks.com).

### ADVERTENCIAS

- Revise el apriete de todos los pernos y tornillos de forma periódica.
- NO LO USE EN TODO TERRENO.
- Siga las instrucciones para un ensamblaje propio, procedimientos de montaje y procedimientos de carga.
- Asegúrese que el portabicicletas y el receptor de su vehículo estén en buenas condiciones antes de cada uso.
- No use ganchos extensibles con este producto.
- No use este producto en un vehículo recreativo o tráiler.
- No use cubiertas o forros para lluvia o viento con este producto.
- Ponga la tijera de la llanta frontal del lado de los brazos de carga frontales.
- No utilice guardabarros bicicleta deneumáticos delanteros con este producto.
- No lo pase a través de un lavado de autos automático.
- El uso incluye correa de seguridad para el neumático delantero en bicicletas con una distancia entre ejes más de 114.3cm y/o un neumático anchura de más de 6cm.

Si tiene usted alguna pregunta o problema con su portabicicletas, por favor contacte a Küat Racks directamente llamando a nuestro número gratuito 1(877)822-KUAT, o por e-mail: [info@kuatracks.com](mailto:info@kuatracks.com).

### AVERTISSEMENTS

- Vérifier le serrage des boulons et des vis périodiquement.
- NE PAS UTILISER À EXTÉRIEUR DU RÉSEAU ROUTIER (OFF-ROAD).
- Bien suivre les instructions de processus d'assemblage, montage et chargement.
- S'assurer du bon fonctionnement du rack et du véhicule avant l'utilisation.
- Ne pas combiner ce produit avec des rallonges de l'attache-remorque.
- Ne pas utiliser ce produit sur un véhicule récréatif ou sur une remorque.
- Ne pas utiliser les housses contre la pluie ou le vent, ni les bâches avec ce produit.
- Placer le crampon du pneu avant à côté de la fourche avant du vélo.
- No utilice guardabarros bicicleta de neumáticos delanteros con este producto.
- Ne pas laisser le rack sur le véhicule lors des lavages automatiques (car wash)
- Utiliser inclus sangle de sécurité pour pneu avant sur les vélos avec un empattement de plus de

# Küat Racks Limited Lifetime Warranty

Küat honors the warranty on all Küat brand products for original owners of the product. Warranty is not transferable.

If a Küat rack that is covered by the terms of this warranty and is determined by Küat, to be defective, Küat will repair or replace the defective parts. Küat may choose in some cases to offer the owner a refund of up to the original purchase price of the product in lieu of repairing or replacing the product.

The Küat warranty does not cover any conditions that are beyond Küat's control. This includes, but is not limited to, the following: excessive loading, improper assembly, improper installation, theft, or any use that is not consistent with the user guide that is included with the product.

The Küat Warranty does not cover normal wear and tear, scratches, cosmetic oxidation, accidents, or damage due to unauthorized repairs or modifications.

If you are the original owner of a defective Küat product, please contact Küat at 1(877)822-5828. A Küat representative will work to quickly resolve the problem. If repairs are necessary, the owner will be responsible for the cost of returning the product to Küat for repair. No product should be returned to Küat without prior authorization from Küat staff.

## LIMIT OF LIABILITY

**THIS WARRANTY ONLY COVERS REPAIR, REPLACEMENT OR REFUND FOR THE COVERED KÜAT PRODUCT. ANY DAMAGE TO VEHICLE OR PROPERTY IS NOT COVERED BY THIS WARRANTY. PERSONAL INJURY IS NOT COVERED BY THIS WARRANTY.**

**LIMITATION OR EXCLUSION OF INCIDENTAL DAMAGE IS NOT ALLOWED IN ALL STATES SO THE ABOVE LIMITATIONS MAY NOT APPLY.**

Küat respeta la garantía de todos los portabicicletas Küat mientras el comprador original sea el propietario de dicho producto. Si el comprador original vende o de alguna otra manera cede el producto a otra persona, la garantía será revocada.

Si un portabicicletas Küat que esté cubierto por los términos de esta garantía está defectuoso, Küat reparará o reemplazará las partes defectuosas a su propio criterio. Küat puede optar en algunos casos por ofrecer el reembolso del precio de compra del product en lugar de repararlo o de reemplazar las piezas defectuosas.

La garantía Küat no cubre ninguna condición que esté más allá del control de Küat. Esto incluye, más no limita, carga excesiva, ensamblaje impropio, montaje impropio, robo o cualquier uso que no sea consistente con las instrucciones que están incluidas con el producto o que están disponibles para el usuario.

La garantía Küat no cubre el uso y desgaste natural, raspaduras, oxidación cosmética, accidentes, operación ilegal del vehículo o modificaciones o reparaciones no autorizadas.

Si usted es el propietario original de un producto Küat defectuoso, por favor contacte a Küat al 1(877) 822-5828. . Un representante de Küat le atenderá para resolver su problema. Si son necesarias reparaciones, el propietario será responsable por el costo del envío del producto a Küat para su reparación. Ningún producto deberá ser enviado a Küat sin previa autorización de un agente de Küat.

## LIMITE DE RESPONSABILIDAD

**ESTA GARANTIA SOLO CUBRE REPARACIONES, REEMPLAZOS O REEMBOLSOS PARA EL PRODUCTO DE KÜAT CUBIERTO. CUALQUIER DAÑO AL VEHICULO O PROPIEDAD O LESION NO ESTA CUBIERTA POR ESTA GARANTIA.**

**LIMITANTES O EXCLUSIONES DE DAÑO ACCIDENTAL NO ESTAN PERMITIDAS EN TODOS LOS ESTADOS, POR LO TANTO ESTAS LIMITANTES PODRIAN NO APLICAR.**

Küat honore la garantie de toute sa gamme du support de la marque Küat tant qu'il demeure la propriété du propriétaire original. La garantie prend fin lorsque le propriétaire original se départit du produit en le vendant ou en le transférant à une autre personne.

Si un article Küat fait défaut alors qu'il est sous garantie, Küat réparera ou remplacera, à sa discrétion, la ou les pièces défectueuses. Küat pourrait choisir dans certains cas d'offrir un remboursement du prix à l'achat au lieu de réparer ou de remplacer la pièce défectueuse.

La garantie Küat ne couvre pas les conditions hors du control de Küat. Celles-ci incluent mais ne sont pas limitées à un chargement excessive, un assemblage erroné, un mauvais montage, le vol ou tout usage qui n'est pas conforme aux instructions (incluses avec le produit) accessibles à l'utilisateur.

La garantie Küat ne couvre pas l'usure normale, les égratignures, l'oxydation, les accidents, l'usage illégal d'un véhicule ou les réparations ou modifications non-autorisées.

Si vous êtes le propriétaire original d'un produit Küat défectueux, prière de contacter Küat au 1-877-822-5828. Un représentant Küat travaillera à la résolution du problème. Si des réparations sont nécessaires, l'acheteur doit assumer les frais d'envoi pour faire parvenir le produit Küat à l'entreprise. Ne retourner pas un produit Küat tant que vous n'obtenez pas l'autorisation d'un représentant de Küat.

## LIMITE DE RESPONSABILITÉS

**LA GARANTIE COUVRE SEULEMENT LA RÉPARATION , LE REMPLACEMENT OU LE REMBOURSEMENT D'UN PRODUIT KÜAT SOUS GARANTIE. LA GARANTIE NE COUVRE PAS LES DOMMAGES AU VÉHICULE, LES DOMMAGES À LA PROPRIÉTÉ NI LES BLESSURES.**

**LES RESTRICTIONS OU LES EXCLUSIONS CONCERNANT LES DOMMAGES ACCIDENTELLES NE SONT PAS ADMISES DANS TOUS LES ÉTATS OU CES RESTRICTIONS PEUVENT NE PAS S'APPLIQUER.**

